

THE VOLATILITY OF EARLY CHILDHOOD EDUCATION IN TODAY'S TIME

Paper ID

IJIFR/V4/ E4/ 001

Page No.

5761-5770

Subject Area

Education

Keywords

Early Childhood Education, Standardization Of Curriculum, Holistic Development, Qualification Of Teachers, Transaction Methods Employed, Parent Involvement

1	R. Prachi Singh	M.Ed. Student Department of Post Graduation Studies Of Education Vijaya Teachers College , Bengaluru-Karnataka
2	Nandini	Assistant Professor, Department of Post Graduation Studies Of Education Vijaya Teachers College , Bengaluru-Karnataka

Abstract

Education begins from the moment child is born and the learning capabilities continue for the rest of their lives. Positive early learning experiences help in the intellectual, social and emotional development of the babies. Children who benefit from early childhood education programs are better prepared for primary school and will reach better education outcomes. Traditional education programs tend to focus on primary education, there is increasing awareness of the importance of nutrition and educational skills in early childhood development. Development agencies and governments are looking closely at how early childhood development can be framed in development goals. At each stage nutrition, care and health support is important along with the educational content. There are few issues related to ECCE like poverty, standardization of curriculum, holistic development, and qualification of teachers and so on. Parent as well as teachers play an important role to overcome the issues related to ECCE. Parents should evaluate a child's unique personality before determining which program is best suited for their child. If young children are molded and trained well during pre-school, then there will not be any dropouts in the high school and also have fewer behavioral problems. This article looks at the importance and issues related to ECCE.

I. INTRODUCTION

Education, in a very general sense can be summed up at a basic level as referring to an experience or act that has a formative effect on the mind, character or physical ability of an individual. In the sense that it is formative means that education is serving to form



something and particularly something that will have a long-lasting effect on the person's mind and faculties. The most obvious example of this is the ability to understand and use language and mathematics a skill which is then utilized throughout an individual's life.

Education begins from the moment the child is brought home from the hospital and continues on when the child starts to attend playgroups and kindergartens. The learning capabilities of humans continue for the rest of their lives but not at the intensity that is demonstrated in the preschool years. With this in mind, babies and toddlers need positive early learning experiences to help their intellectual, social and emotional development and this lays the foundation for later school success.

In this regard the Indian Education System has many stages such as the Nursery, the Primary, the Secondary, the Higher Secondary, the Graduation, and the Post-Graduation. The Preprimary or the Nursery has the Lower Kindergarten and the Upper Kindergarten, where the basic reading and writing skills are developed. The Primary school has the children between the ages of six and eleven. It has the organized classes of one to five. The Secondary school children are between the ages of eleven and fifteen and the classes are organized from six to ten. The higher secondary school students are between the ages of sixteen and seventeen and the classes are organized as eleven and twelve. In some states, the classes between six and eight are also referred as the Middle schools and those between eight and ten are referred as the high schools. There are many different streams available after secondary education. The Higher Education in India aims at providing education to specialize in a field and includes many technical schools, colleges, and universities. The schools in India are controlled by various boards such as the Central Board of Secondary Education (CBSE) board, the Council for the Indian School Certificate Examinations (CISCE) board, the state government boards, the National Open School and the International schools.

II. EARLYCHILDHOOD

Early childhood is a crucial stage of life in terms of a child's physical, intellectual, emotional and social development. Growth of mental and physical abilities progress at an astounding rate and a very high proportion of learning take place from birth to age six. It is a time when children particularly need high quality personal care and learning experiences.

2.1 EARLY CHILDHOOD CARE AND EDUCATION (ECCE)

It is gaining importance universally for its role in laying a strong foundation for the holistic development of a young child. It is conceptualized as an integrated provision for children 3 from prenatal stage to 8 years, which addresses a child's need for care, education, nutrition and health holistically, in consonance with a life cycle approach. These needs may be met through one unified source or program or through different sources, which may each converge on the child, the mother and the child's physical and social environment, as a comprehensive mode.

Sub stages of ECCE

- (a) An Infant-toddler stage for children 3 years and below, who require family or crèche based protective, consistent and responsive care and a stimulating environment, along with adequate nutrition and health inputs;
- (b) An Early Childhood Education (ECE) stage, also known as the Preschool/Pre-primary school Education stage for children between 3 to 6 years, who require a centre/school based pre-primary education programme.
- (c) Early Primary stage for children between six to eight years. Although children between six to eight years are expected to be in primary school, they continue to be considered in the Early Childhood stage because they have developmental characteristics in common with the younger child.

The smooth transition of these children from preschool to school becomes an area of concern and priority, in view of the significant drop outs in the early primary grades. At each of these sub stages, nutrition, care and health support continue to be important inputs, along with the educational content.

2.2 IMPORTANCE OF ECCE

Most childhood education specialists claim that young children learn best when they're not pushed too hard, they have an opportunity to interact with their peers, and their parents and instructors treat them kindly. Likewise, children learn best when instruction and educational activities are only a small portion of their days. This is especially true of children enrolled in pre-school programs since it's not good for young children to be separated from their parents for extended periods of time. Children usually do not benefit in programs with inexperienced teachers and large classroom sizes.

Children taught at an early age usually benefit in the following ways: improved social skills, less or no need for special education instruction during subsequent school years, better grades, and enhanced attention spans. Likewise, some researchers have concluded that young children enrolled in pre-school programs usually graduate from high school, attend college, have fewer behavioral problems, and do not become involved with crime in their adolescent and young adult years. The research detailing these benefits was completed during the 80's. In addition to benefiting children experiencing normal development, it was also shown that children with learning or other physical disabilities benefit immensely from pre-kindergarten education. Also, children with parents highly involved in their pre-kindergarten education do not experience the same positive results from Head Start programs as children coming from homes where it's not as much an emphasis. Children taught how to speak a second language during their early developmental years are also in a better position to learn English at a young age. Many people do not feel the government should determine whether children should be required to receive formal pre-kindergarten education. One reason for this is children who are educated by their parents during their early developmental years' experience the same benefits as children enrolled in pre-school programs, especially children receiving a lot of attention from parents. Parents deciding to educate their young children themselves should utilize creative ideas and activities when educating them.

No matter the differences in opinion about formal pre-kindergarten education, children benefit from receiving some type of education during their early developmental years. However, there is not one-size fits all instruction best suited for all children. While some children benefit immensely from pre-school, it may not be the best educational setting for other children. In most cases, children benefit most by receiving educational instruction from their parents. Parents must evaluate a child's unique personality before determining which program is best suited for a child since not all programs benefit children the same way.

III. HOW TO MAKE SURE THAT A CHILD IS IN A GOOD CURRICULUM?

National Association for the Education of Young Children (NAEYC) suggests looking for these 10 signs to make sure your child is in a good classroom. Children spend most of their time playing and working with materials or other children. They do not wander aimlessly and they are not expected to sit quietly for long periods of time.

2. Children have access to various activities throughout the day. Look for assorted building blocks and other construction materials, props for pretend play, picture books, paints and other art materials, and table toys such as matching games, pegboards, and puzzles. All the children should not necessarily all be doing the same activity at the same time.

3. Teachers work with individual children, small groups, and the whole group at different times during the day. They do not spend all their time with the whole group.

4. The classroom is decorated with children's original artwork, their own writing with invented spelling, and stories dictated by children to teachers.

5. Children learn numbers and the alphabet in the context of their everyday experiences. The natural world of plants and animals and meaningful activities like cooking, taking attendance or serving snack provides the basis for learning activities.

6. Children work on projects and have long periods of time (at least one hour) to play and explore. Worksheets are used little, if at all.

7. Children have an opportunity to play outside every day. Outdoor play is never sacrificed for more instructional time.

8. Teachers read books to children individually or in small groups throughout the day, not just at group story time.

9. Curriculum is adapted for those who are ahead as well as those who need additional help. Teachers recognize that children's different backgrounds and experiences mean that they do not learn the same things at the same time in the same way.

10. Children and their parents look forward to school. Parents feel secure about sending their child to the program. Children are happy to attend; they do not cry regularly or complain of feeling sick.

IV. ISSUES AND CONCERNS IN EARLY CHILDHOOD EDUCATION

Since the pre-independence era, socialist, communists, educationists and even the government has been continuously working in the education sector for the betterment of

children but still optimum results are not reaped. We do not say progress had not been made but still a new approach for quality education is required in the early childhood education. Some of the primary concerns of the present era are: -

i.) Poverty

J. Bank (1997) in his paper “Teaching Strategies for Ethnic Studies” stated that India is a developing country and despite of diversity, poverty is also a limiting factor which in some cases may hamper the development of a child in his early years. Rather poverty is one aspects of diversity that is gathering more attention as the number of children living in poverty rises. Very little emphasis has been placed on working with students from poverty, even though poverty crosses all racial and ethnic boundaries. But, Pellino (2006) found out that children of poverty are more likely to attend schools with fewer resources as well. Even though teachers might not be able to change someone’s financial circumstances, they can affect student’s success by learning to identify and use the resources that the students do have.

ii.) Wages

In today’s time when everybody is after money the wages in this sector are not satisfactory enough to motivate professionals to enter into this field. Sharon L.K., N. Richard and H. Carol (2002) has also suggested that early care and education staff should earn wages linked to those earned by public elementary school teachers, with salaries varying depending on locale. They recommended that we use the starting salaries for an elementary school teacher with a Bachelor of Arts or science degree as an anchor point. That is, the starting hourly pay for a child care teacher with a Bachelor’s degree should be equal to that of an elementary school teacher with the same levels of training, professionalization and work responsibilities. This is one of the primary reason that male professionals are not keen to enter in this field as in our society they are considered to be the main bread earner and with such low wages it will be difficult for them to meet the required parameters of their family sustainability.

iii.) Teacher’s qualification

Bowman, B., M.S. Donovan and M.S. Burns, eds., and Committee on Early Childhood Pedagogy, National Research Council, 2000 recommends that all groups of young children (age 3 and older) should have a teacher with Bachelor’s Degree including Early Childhood Specialization.

It should be seen that Early Childhood teachers have training and professional competence. Teachers with comparable qualifications and experience should receive the same salary and benefits, whether teaching in a public elementary school or in early childhood education. Staff should have a range of formal qualifications, with a portion of center teachers and family child care teachers holding bachelor’s degree and administrators holding advanced degrees. Entry level positions should be maintained so that pre service qualifications do not become a barrier to individuals from low socio economic strata or minority groups seeking to enter the field.

iv.) Curriculum and Transaction Methods Employed for Teacher Education

A rapid review of the curriculum, largely on the basis of the titles of the papers/courses, indicates that the overall trend is to follow a Child Development perspective with, in some cases, an additional academic focus also, which tends to make it developmentally inappropriate. However, in most cases while basic content is in order, some prominent gaps that may be identified are inadequate coverage of (a) the current Indian policy scenario and issues in ECCE and (b) emerging and state of the art global knowledge with particular reference to current research in neuroscience, constructivist approaches in pedagogy, importance of school readiness and emergent literacy, social inclusion and so on. The study also raises a dilemma whether the teacher education curriculum should be prepared centrally by curriculum framers in the interest of uniform standards, despite wide diversities in contexts or alternatively, a curriculum framework should be prescribed centrally with provision for teacher educators to adapt and develop their own curriculum in tune with their respective contexts. While the second alternative is logically more desirable, it would require a systematic programme of professional development of teacher educators in this area as a precondition to enable them to do this effectively.

In terms of methods employed, the study indicates an overall dominance of the lecture method and blackboard teaching in the classrooms as actually observed, although teacher educators and academic heads reported use of more participatory methods. What this perhaps indicates is that the awareness regarding participatory methods may have improved over the years, but this has not yet translated into actual practice in the classrooms. These observations definitely point to the need for teacher educators to move towards more progressive and interactive and adult learning methods of teaching learning. A clear lacuna identified in the study with regard to teacher educators is the complete dearth of resources available to them for professional development across institutions, particularly for procurement of learning materials, deputations for workshops and conferences, exposure visits or membership of professional organizations.

v.) Decreasing Age Range of the child in preschool

Previously, the family system in India was the joint family system, the mothers used to be with the child for most of the time but the times have changed now, the families are not only becoming nuclear but even the mothers are stepping into the jobs. This leaves them with less time to be spent with their children. Today, the parents have found an easy solution to escape from this liability by getting their child enrolled into a preschool at a very young age even when their child's separation anxiety has not got settled. For their own professional gains they are neglecting their roles as parents. Thus, the age range instead of going upwards it is going downward.

vi.) Parent Involvement

Parent involvement with child's education has become a major issue in this era of increasing concern about the quality of education. Parent involvement includes several different forms of parental participation in child's life, education as well as his/her daily tasks. Parent involvement during early childhood period helps the child to form and shape his or her own academic self-concept. Pre-school and pre-school teachers play a vital role in involving the

parents with the child's curriculum thus; they should be well trained to do so. But it is often found that lack of planning and lack of mutual understanding between teachers and parents results in ineffective parent involvement.

vii.) Multiculturalism

Considering our own country India, the land of multiculturalism and diversity with so many languages, different attires, cuisines and various codes of conducts. A country that has distinct cultures right from Kashmir to Kanyakumari sometimes creates challenges for the preschool teacher. They have to deal with a number of culturally and linguistically diverse children in a single classroom, thus providing them appropriate education and care and also have to work effectively with their families. Despite numerous efforts in schools, administration, and teacher training still majority of classroom teacher believe that they are not able to meet all the needs of the children and families from diverse backgrounds as stated in the paper "Preparing teachers for Culturally Diverse Schools", by C.E. Sleeter (2001). Hence measures are required in this field to train the teachers working with such group of students. They should be sensitive enough to bring best out of a child despite of his/her limitations.

viii.) Quality of preschool education

Today's reality is that even with increased communities to ECE from without the government, quality remains embarrassingly poor. Staff salaries are inadequate and high quality care is not affordable for most parents. As it was stated by Layzer and Collins (2000) that, most states meet or exceed the quality set aside under the child development fund. They fund various small efforts without a coherent strategy to address the underlying causes of poor quality. To address the situation, many in the field are studying what is needed, finding innovative approaches to revenue generation and considering inventive financing schemes (Mitchell, Stoney and Dichter 2001). While inadequate resources are absolutely the first and major problem, they are not the only issue. How the resources are spent is also critical. In spite of maybe important efforts to improve quality, funds have been inadequate and strategies insufficiently comprehensive to make a real difference in the quality of care most children receive. It is as though we keep planting seeds in the same flower bed year after year without fertilizing the soil, and then wonder why the flowers do not thrive.

ix.) Commercialization of the education

Urbanization and industrialization has not even left the educational sector untouched. One can witness this boom with mushrooming of child related centers in every nook and corner of the country. Big brands and companies have now entered the market with the motive of making profits. These companies through their marketing strategies provoke people to take up these ventures but at times these people are not themselves well equipped/ qualified.

The once known as "temples of education" are now transformed in to a five star hotels. The intention is to impress the high-flying parents who have the money to afford big fees but have no time for their children. The attractive flashy brochures with quotes by the famous educationists are enough for such parents to get convinced about the kind of education school is showing to impart to their children. This has encouraged some of the schools to go

few steps further and they have hired the brand managers to market their schools. It is interesting to notice that every coming up five star school claims that its aim is to develop inquiring, knowledgeable and caring young people who will help to create a better and more peaceful world through intercultural understanding and respect. There is a boom of the air-conditioned business houses calling themselves schools with funky names in every nook and corner. All of them talk about the provision of five star facilities. They are spending lavishly on advertising about the facilities and the beautifully architected buildings of brick and mortar. The commercial agents of the education are hardly ever bothered about the effective teaching of values and creating a really good school. They have a clear goal of making money. No one is talking about the life of a school. A good school does not emerge like a pre-packed frozen dinner stuck for few seconds in a microwave. A good school develops from the slow simmering of carefully blended ingredients. One consistent ingredient is the philosophy and culture within the school environment. The environment should be effective enough to formulate the norms, beliefs and values in to modes, standards and rules of operation.

x.) Beyond Assembly Line

Given that our society and lifestyle is changing at a startling pace, parents want to provide a relevant foundation to their children's education. The focus of pedagogies is shifting from dishing out inert clones off an assembly line, to producing thinking and dynamic individuals. Teachers today are recognizing the importance of early childhood development, as well as the complementing aspects of individual growth, peer interaction, self-reliance and learning through exploration rather than through evaluation and assessment. This has become central to the teaching system. Accordingly, schools and preschools across the country are implementing the nuances of these ground-breaking approaches in teaching.

Standardization of curriculum

The focus, hence, is on catering to overall child development rather than academic readiness or cognitive development alone. However, ensuring quality benchmark parameters in preschools undoubtedly aims at upscaling standards through standardisation. Unfortunately, when it comes to local customisation and administering a curriculum tailored to suit the specific learning needs of a child, standardisation of curriculum might come as a challenge. It, however, does not mean focusing on academics alone, but paying equal attention to developing life-skills, offering fun-based exploratory learning activities to the child during his formative years.

xi.) Holistic development

A guideline for preschool standardisation and draft policy 2012 for the National Early Childhood Care and Education is a major push in this direction. The ECCE Policy brings in the role of the Indian Government to ensure comprehensive holistic development for all children till the age of six years and preparing a child for formal schooling. While the policy looks at initiating reforms and measures, the scope of early childhood program goes far beyond basic literacy programs.

xii.) Making Children School-Ready

In addition to overall awareness programs on health, hygiene and nutrition, making the child school-ready is equally important. ECCE looks at building social, behavioral and emotional competencies. Helping to develop a mind that is attentive to appropriate and child-centric Quality care

In India, ECCE initiatives are offered through various public and private centres called Anganwadis, Balwadis, playschools, preschools, day care centres, crèches, kindergartens, and preparatory schools. ECCE, however, has not yet seen much of consistent quality drive in our country, more so, in the absence of steadfast centralized policies and regulatory bodies. The access to ECCE is to be transformed into quality care with optimal hygiene, development, and fun. On one hand, the vast cultural, social, and contextual diversities account for customization and personal care, while on the other, freezing quality benchmarks relies on formulation of standard guidelines, which in itself is a challenge.

IV. CONCLUSION

Given the initiatives that a few of the pioneering private and public players have taken, we have reasons to believe that ECCE is headed for a brighter and better future in our country where it is not just a day care alone but a dire necessity for overall development of children. Of course, certain issues will always remain critical, such as standard audits and compliance with optimal hygiene and infrastructural requirements. While optimal child-teacher ratio should be observed, sensitivity to a child's need for emotional and social development is also important. Interestingly, if we compare the Indian scenario with the global one, we are far from reaching our goal. Early Childhood Care and Education has seen effervescent trends on an international platform. Organizations such as the OMEP (Organization Mondiale pour educationPréscolaire), which is an international, non-governmental and non-profit-making organization, is working on all aspects of early childhood education and care. It defends and promotes the rights of children to education and care worldwide and supports activities improving accessibility to high quality education and care. Today, India needs initiatives such as OMEP to focus on issues related to Early Childhood Care and Education. It is important that when considering an early education facility, caregivers and teacher in the facility have knowledge of the cultural supports for the language and literacy learning of the children and families they are serving. They need to have sufficient skills in guiding small groups of children in order to give full attention to individual young children's language and literacy efforts. They need to be able to draw out shy children while they help very talkative ones begin to listen to others as well as to speak. Caregivers or teachers need to arrange environments that are symbol rich and interesting without being overwhelming to infants and toddlers. Even the simplest exchange becomes a literacy lesson when it includes the warmth of a relationship coupled with words, their concepts, and perhaps a graphic symbol. The curriculum should include more opportunity for individual growth of the student teacher through inclusion of tutorials, individual and team assignments and presentations, and a sizeable component of self-development opportunities. Curriculum, or the content of what children learn, is central to supporting and strengthening young

children's learning and development because it is the "front line" of children's experiences. Curriculum is different from beliefs about children, pedagogy, learning standards, and children's skills. Nonetheless, curriculum is central not only to the knowledge and skills children gain, but also to the application of particular pedagogical approaches and to the nature of teacher/caregiver-child interactions. With increasing numbers of children in early care and education programs, coupled with the increasing focus on school readiness, effective curriculum is crucial. Moreover, as the press for accountability increases, children must be exposed to the content for which they and their teachers will be held accountable. Commercialization is becoming a major concern which if not handled properly could lead to serious consequences. The professionals should be responsible while planning and developing for young children's education programs. They should be responsive towards child's diverse needs since it is not possible to develop a quality program without understanding the basic needs of a child. Curriculum, intuitive to perceptions through adherence to life-skills, curious to explore and learn through fun-based exploratory learning activities, and to build a body that works with the correct reflexes in children through activities that develop gross motor skills, ECCE is at the overall grooming of a child.

VI. REFERENCES

- [1] Mizala, A. and H. Nopo 2012. Evolution of Teachers' Salaries in Latin America at the Turn of the 20th: How Much Are They (Under or Over) Paid? Discussion Paper Series. Bonn, Germany, Institute for the Study of Labor.
- [2] Mulkeen, A. 2010. Teachers in Anglophone Africa: Issues in Teacher Supply, Training, and Management. Washington, DC, World Bank.
- [3] Tobin, J. "Quality in early childhood education: An anthropologist's perspective". Early Education and Development 16. no. 4. 2005. pp. 421-434.
- [4] UNESCO Bangkok. Education for All Mid-Decade Assessment. Part 2: South Asia subregional progress and challenges. Bangkok: UNESCO, 2009.
- [5] <https://www.expatriate.or.id/info/earlychildhoodeducation.html>
- [6] <http://education.newkerala.com/india-education/india-education.html>
- [7] <http://drpfconsults.com/issues-in-education-early-childhood-education/>
- [8] <http://www.educationcorner.com/importance-of-early-childhood-education.html>
- [9] <http://unesdoc.unesco.org/images/0023/002327/232721E.pdf>
- [10] <http://www.child-encyclopedia.com/preschool-programs/according-experts/preschool-programs-effective-curricula>
- [11] <http://ecrp.uiuc.edu/v11n1/azzi.html>
- [12] <https://www.nap.edu/read/9745/chapter/8#236>
- [13] <http://www.deccanherald.com/content/360703/challenges-early-childhood-care.html>

To Cite This Article

Singh, P.R., Nandini (2016) : "The Volatility Of Early Childhood Education In Today's Time" *International Journal of Informative & Futuristic Research (ISSN: 2347-1697)*, Vol. 4 No. (4), December 2016, pp. 5761-5770, Paper ID: IJIFR/V4/E4/001.

AWARENESS AND PREPAREDNESS ABOUT GOODS AND SERVICES TAX AMONG THE RETAIL BUSINESSES IN INDIA - AN EMPIRICAL STUDY OF HUBLI-DHARWAD CITY

Paper ID

IJIFR/V4/ E4/ 005

Page No.

5771-5778

Subject Area

Management

Keywords

Goods and Services Tax (GST), VAT, Direct and Indirect Tax

Dr. Ramesh R Kulkarni

Associate Professor
Department of Management Studies
Karnatak University, Dharwad-Karnataka

Abstract

After a prolonged debate over the last decade or so, the Goods and Services Tax (GST) is set to be a reality in India. It is the most important tax reform ever carried out in the country post-Independence. The upcoming tax system will pave way for a one-country one-tax regime and lead to a single unified market across 29 Indian states. According to experts, GST will be beneficial for the Indian economy as a whole and it is expected that the gross domestic product (GDP) of the country will increase by 1-2% over the years. The new tax system is not only seen as the main source of revenue for the government, but it is also expected to change the way how the retail traders do their business and comply with the tax slabs. Even though the whole country, be it policy makers in the Parliament, trade and businesses or common man have been debating about the introduction of GST as a new system of taxation that will replace existing value added tax system in the country, there are some sections of the society that are still not aware of it. An attempt has been made in this study to find out the awareness about the new tax system among retail traders in a city like Hubli-Dharwad. Interestingly, the study has found that a majority of the respondents are aware of the new tax reform; a large number of those traders are still unprepared to adopt the new structure. While the new tax structure is likely to be implemented from the next financial year (2017-18), the retailers are yet to prepare themselves as to how they will comply with it.

I. INTRODUCTION

Major source of revenue for any country would be taxes that the governments impose on its people and businesses. India also gets its revenue from taxes, both direct and indirect taxes such as, Income Tax, VAT, Service Tax, customs and excise duty among others. The government of India has been continuously reforming its tax structure since independence.



The Government has been changing the name and form of these taxes from time to time. So also the extent of these taxes depending upon its Fiscal deficit and Foreign exchange requirements. The passage of Goods and Services Tax Bill by the Parliament recently is the biggest taxation reform carried out by the country since Independence.

The new Constitution Amendment Bill for Goods and Services Tax (GST) has been approved by The President of India post its passage in the Parliament (Rajya Sabha on 3 August 2016 and Lok Sabha on 8 August 2016) and ratification by more than 50 per cent of state legislatures. The Government of India is committed to replace all the indirect taxes levied on goods and services by the Centre and States and implement GST by April 2017. With GST, it is anticipated that the tax base will be comprehensive, as virtually all goods and services will be taxable, with minimum exemptions.

GST will be a game changing reform for the Indian economy as it will create a common Indian market and expected to reduce the cascading effect of tax on the cost of goods and services. It will impact the tax structure, tax incidence, tax computation, tax payment, compliance, credit utilisation and reporting, leading to a complete overhaul of the current indirect tax system. GST will have a far-reaching impact on almost all the aspects of the business operations in the country, for instance, pricing of products and services, supply chain optimisation, IT, accounting, and tax compliance systems.

With the implementation of GST, which is likely to be done by April 2017, three sectors will benefit the most: retail, FMCG and consumer durables companies and logistics business. Now, it is time to introspect whether these sectors are completely aware of this change to come. Especially the retail sector is the most nearest sector to common public, needs to have immediate awareness about the tax norms.

Therefore, an attempt is made here to understand the awareness about GST among the retail businesses as well as their preparedness towards to adopt it in the country, by choosing Hubli-Dharwad cities as an empirical study area. Following research questions were raised to find out the objective of this study.

1. Whether the retailers in these twin cities are aware of the changing tax structure from VAT to GST?
2. How prepared are the retailers in adopting GST?

II. OBJECTIVE OF THE STUDY

The general objective of the study is to assess the awareness of Goods and services Tax (GST) implementation in the country, which is broken into two specific objectives:

- To study the awareness about GST amongst the retail businesses in the town.
- To assess the perception of retailers towards GST

III. RESEARCH METHODOLOGY

Descriptive data analysis techniques are employed to analyse the data collected from the primary sources by doing a sample survey of retailers in the town.

Instrument: A questionnaire is designed having 20 questions exploring the awareness and preparedness of the retailers about GST. Then the questionnaires were filled by the researcher through a close interaction with the shop keepers and the retailers at their location.

Sample: A sample of 120 retail businesses has been chosen from Hubli-Dharwad city, which is situated in northern part of Karnataka state, approximately 425 km away from Bengaluru. It is a semi commercial twin city with three Universities functioning and newly created IIT has been started from the year 2016-17. Having a small airport along with both rail and road means of transportation available. The respondents were chosen on convenience basis and were studied using questionnaire method of data collection. The questionnaire was instrumented on a sample of 120 retailers doing business in the twin city of Hubli-Dharwad by adopting convenient sampling method.

Analysis: The responses are further captured into printed questionnaires and the required primary data has been extracted from it using coding and tabulation techniques. The quantitative data analysis has been done using SPSS package is applied to explore and identify the awareness and preparedness about GST, the perception of retailers towards the new tax system. Further data analysis tools like averages, percentages, graphs such as bar, pie-charts are worked out to assess the awareness of GST.

IV. REVIEW OF LITERATURE

What is GST? The GST is basically an indirect tax that brings most of the taxes imposed on most goods and services, on manufacture, sale and consumption of goods and services, under a single domain at the national level. In the present system, taxes are levied separately on goods and services. The GST is a consolidated tax based on a uniform rate of tax fixed for both goods and services and it is payable at the final point of consumption. At each stage of sale or purchase in the supply chain, this tax is collected on value-added goods and services, through a tax credit mechanism. (<http://www.gstindia.com/>)

1. GST is a transparent Tax and also reduces number of indirect taxes. With GST implemented a business premises can show the tax applied in the sales invoice. Customer will know exactly how much tax they are paying on the product they bought or services they consumed. (Times of India, report)
2. GST will not be a cost to registered retailers therefore there will be no hidden taxes and the cost of doing business will be lower. This in turn will help Export being more competitive
3. GST can also help in diversification of income sources for government other than income tax and petroleum tax. .(Express News Service | Updated: October 19, 2016 8:29 am)
4. Under goods and services tax, the tax burden will be divided equally between manufacturing and service sectors. (Express News Service | Updated: October 19, 2016 8:29 am)

5. In GST system both the central GST and State GST will be charged on manufacturing cost and will be collected on the point of sale. This will benefit people as prices will come down which in turn will help companies as consumption will increase.
6. Biggest benefit is that multiple taxes like octroi, central sales tax, state sales tax, entry tax, licence fees, turnover tax, etc will no longer be present and all that will be brought under the GST. Doing business now will be easier and more comfortable as various hidden taxation will not be present. (Express News Service | Updated: October 19, 2016 8:29 am)
7. More than 150 countries have implemented GST and each of them faced rise in Inflation for next 3-5 years.(Express News Service | Updated: October 19, 2016 8:29 am).
8. The benefits of GST for retailers and businesses are easy compliance, uniformity of tax rates and structure, removal of cascading, single and transparent tax as per report in GSTindia website (<http://www.gstindia.com/about/>).

V. ANALYSIS AND FINDINGS

An elementary descriptive analysis is made here to assess and explore the factors restricting the online buying decision of students. The analysis of the data flows into two parts, in the first exploring the demographic information of the retailers and in the second part the awareness about the GST among the retailers will be analysed using descriptive analysis. Table-1 is prepared to describe demographic information of the respondents. The respondents under study were chosen from Hubli-Dharwad city, on convenience sampling basis. Care has been taken to identify the retail businessman for the study. The questionnaire was self administered by the researcher by a closed interaction with the retailers under study.

1. From Table-1 it is clear that, 65% of the retailers are aware of GST and hence the status of GST is showing fair percentage awareness about GST among the retailers. Thus our first objective is fulfilled to verify whether the retailers are aware of this new tax reforms. In the second part of analysis the Table-2 given below summarises various sources identified in the study through which the respondents have got awareness about the new tax.

Table- 1: Demographic information of Respondents

Demographic items	No of Respondents	Percentage
No of Respondents	120	
Sex		
Male	98	56.7
Female	21	43.3
Age group		
20-30	21	24.5
30-40	19	35
40-50	30	33
50 & above	31	07.5
Marital Status		
Married	118	98.33
Unmarried	02	1.66
Income Level (In Lakh Rupees)		

Below 10	15	12.5
10-200	25	20.83
200-500	55	45.8
500-1000	15	12.5
1000 and above	10	08.3
Awareness about GST		
YES	78	65
NO	42	35
Preparedness about GST		
YES	30	25
NO	84	75
No Response	06	05
Acceptance to the change		
YES	76	63
NO	18	15
No Response	26	22

2. From the Table-1 above we can make out that, 65% of the respondents are aware of the proposed change in tax structure to come from April 2017 in the town. Of them, 60% of the respondents have got the awareness from Media notifications. Others came to know about it from various other sources listed in Table -2 below.

Table 2: Awareness about tax payment

Source of information	Frequency	Percent (%)
Chartered Accountant	12	10
Media	72	60
Government Notification	06	05
Friends & Relatives	18	15
Customers	12	10
Total	150	100

3. Besides that, 50% of the retailers under study opined that they know tax payment is a government regulation and they cannot avoid it. Interestingly 24% of the retailers though is a small proportion as shown in Table-2, is significant percent of the retailers those are still dependent on the Tax consultant's advice and doesn't have awareness about the new tax structure. Only 10% of them are of the opinion that tax payment is a national responsibility and the remaining are just take it light approach retailers.

Table 3: Reasons for payment of tax ?

Why Do we pay tax	Frequency	Percent (%)
Govt. Regulation	60	50
As a National Responsibility	12	10
Advice by Tax consultant	29	24
As a routine	19	16
Total	120	100

Since, there are many unregistered business firms, many of their customers have shifted to those firms and as a result, their sales/revenue has deteriorated significantly. Similarly, as the controlling system of the authority is not well-developed, there are different business firms in selling their product and services VAT free which is affecting their businesses badly. Some of the respondents have also explained that the introduction of VAT has brought them different complexities in their day-to-day activities and their record keeping system. As a result, they have been forced to hire additional professional employees thereby causing additional expenses.

4. From the Table-2 above, we can easily make out that, majority of the respondents have known about GST through Media.

Table-4: Opinion of the respondents on the awareness about GST.

Benefits of GST	Low	Neutral	High	N	Mean	Std. Dev	Std. Error Mean	t	df	Sig. (2-tailed)
Advantageous	22	25	73	120	2.43	.785	.072	19.886	119	.000
Transparancy	22	31	67	120	2.33	.769	.070	18.881	119	.000
One Point Payment	22	17	81	120	2.49	.789	.072	20.723	119	.000
Tax_Reduction	28	17	75	120	2.39	.843	.077	18.082	119	.000
No_Cascading	22	75	23	120	2.44	.786	.072	20.082	119	.000
Reduces_Evasion	22	81	17	120	2.49	.789	.072	20.723	119	.000
Easy_workout	22	67	31	120	2.38	.779	.071	19.347	119	.000

5. From the Table 4 above, it is clear that, the p-value in testing a hypothesis that, people are not aware about the benefits of GST such as Advantageous, transparent, low tax, no cascading effect, low evasion and ease in workout etc is less than the 0.05 the level of significance and hence ensuring the rejection. This means that there is a significant awareness among the people that GST is beneficial in one or the other way for retailers if implemented. In other words majority of the respondents under study were of the opinion that, GST will bring reforms such as transparency, reduction in tax, and ease in working out tax. They also opine that GST will bring control on tax evasion.

6. Preparedness: The success of any tax reforms depends upon how convenient it is to be paid by the tax payer. Basically the mode of payment for such taxes plays an important role in the success of collection of tax. Also how much prepared are these tax payers to make tax payment decides the success of such reforms. The current study reveals that only around 30% of the respondents are prepared for the tax payment and remaining have various opinions on it. Further, it is understandable that the extent of success in settling GST payments depends on the sophistication of the mode of payment. More sophisticated is the mode of payment is the smooth and timely settlement of the payment of tax is expected from the payer. In this pursuit following Table 5 throws light on the various modes of

payment which retailers have been practising so far and are prepared for the future to pay tax.

Table 5: Preparedness of the retailers for GST in mode of payment of tax

Mode of payment	Frequency	Percent
Self Payment through e-portal	36	30
Self By Advance Tax method	48	40
Settlement as per CA's advice	36	30
Total	150	100.0

7. About 30% of the retailers are aware and prepared to pay tax online, while the percentage of retailers still prefer to pay through an old conventional method of advance tax paying system as per the advice of the CA or tax consultant shows that there is no preparedness for self payment of tax by the retailers under the study. This Table prompts that, though people are aware of tax payment and the upcoming reforms in it, they need to be trained or made aware about the ways and means of calculating the tax (GST) so as to make tax payment more easy and the GST to be more successful.

VI. LIMITATIONS

Time, cost and resources are again the main limitations of the study.

1. The study was restricted to Hubli–Dharwad city the regional disadvantages may affect the results to some extent.
2. Respondents' views and opinion may hold good for the time being and may vary in the future.
3. The opinion of the respondents may change sharply depending upon the education level and nature of the business being done.

All of the above may be scope for further research with a variety of variables and their impact on acceptance of such tax reforms by the people of the country.

VII. CONCLUSIONS

GST is set to emerge as the main source of government revenue. Nowadays, many countries in the world have adopted GST as part of their tax system. However, in India its implementation is challenging. From this empirical study, it can be easily make out that, the awareness about GST is fairly high about 65% and the preparedness is in opposite direction with only 25% of the respondents said they are prepared to pay GST. There is still good percent of retailers who have resistance for change is upto 22%. Where as respondents have shown fair bit of awareness about the benefits of GST such as transparency in tax, one point payment, reduction in tax, reduction in cascading effect, ease in workout etc. Therefore two points for the policy makers may be prompted as an outcome of this paper.

VIII. RECOMMENDATIONS

Based on the analysis of the data collected under the limited scope of this study the following recommendations may be considered at the policy level.

1. Since only about 30% of the retailers are aware and prepared to pay tax online, there is a scope for improving this percentage by spreading awareness among the retailers by adopting suitable campaigns on tax awareness.
2. Though retailers under study have shown great awareness about the change that is going to come, but major proportion of them (60%) are still dependent upon the tax consultants' advice for making tax payment and are not auto tax paying business still. This also prompts at the policy makers to launch effective campaigns to train such small tax payers in such a way that they would make payment as a routine instead of one time settlements at the end of the accounting year.

Needless to say that, these recommendations are again limited to the scope of the study area and many such steps must have already been taken the Government at the Centre.

REFERENCES

- [1] The Role of the Goods and Service Tax (GST) in Development of Indian Economy by Bharati Kiyawat¹, Shruti Kiyawat², International Journal of Science and Research (IJSR)
- [2] Goods and Services Tax (GST) Bill, explained, By: Express News Service | Updated: October 19, 2016 8:29 am
- [3] Ernst & Young LLP | Assurance | Tax | Transactions | Advisory
- [4] "Impact evaluation of Value Added Tax on Uttar Pradesh", by Princy Bansal Delhi School of Economics
- [5] A Study On Impact Of Value Added Tax (Vat) Implementation In India Dr.A.Jayakumar., Ph.D ,Associate Professor and Former Controller of Examinations ,Department of commerce ,Periyar University,Salem.
- [6] The impact of GST on the retail sector in India, By Indiaretailing Bureau, August 4, 2016
- [7] <http://www.gstindia.com>

To Cite This Article

Kulkarni, R.R., (2016): "Awareness And Preparedness About Goods And Services Tax Among The Retail Businesses In India - An Empirical Study Of Hubli-Dharwad City" *International Journal of Informative & Futuristic Research (ISSN: 2347-1697)*, Vol. 4 No. (4), December 2016, pp. 5771-5778, Paper ID: IJIFR/V4/E4/005.

POWER FLOW CONTROL IN A TRANSMISSION LINE USING D-FACTS DEVICES

Paper ID

IJIFR/V4/ E4/ 013

Page No.

5779-5789

Subject Area

EEE

Keywords

Power Flow Control, Distributed Flexible AC Transmission Systems, TCSC

1 st	Mereya Baby	Assistant Professor Department of Electrical & Electronics Engineering Viswajyothi College of Engineering and Technology, Vazhakulam- Ernakulam, Kerala
2 nd	Smitha Jacob	

Abstract

Flexible AC transmission systems (FACTS) devices can control power flow in the transmission system to voltage source as it can inject an almost sinusoidal voltage of variable and controllable amplitude and phase angle, in series with a transmission line. Most of the injected voltage, which is in quadrature with the line current, provides the effect of inserting an inductive or capacitive reactance in series with the transmission line. This variable reactance influences the electric power flow in the transmission line. This paper illustrates the flexibility of control that is achievable with D-FACTS devices. D-FACTS converters are single-phase and floating with respect to the ground, there is no high-voltage isolation required between the phases. The impact of installing D-FACTS devices is examined by studying the sensitivities of power system quantities such as voltage magnitude, voltage angle, bus power injections, line power flows, and real power losses with respect to line impedance. Sensitivities enable us to quantify the amount of control D-FACTS devices offer to the system. Independently controllable lines are selected for power flow control and appropriate locations to install D-FACTS devices for line flow control are determined. Then, D-FACTS device settings are selected to achieve desired line flow objectives.

I. INTRODUCTION

A Flexible AC Transmission System incorporates power electronics and controllers to enhance controllability and increase transfer capability. This paper introduces the concept of a distributed static series compensator that uses multiple low-power single-phase inverters that attach to the transmission conductor and dynamically control the impedance of the transmission line, allowing control of active power flow on the line. The DSSC inverters are self-powered by induction from the line itself, float electrically on the transmission



conductors, and are controlled using wireless or power line communication techniques. Implementation of system level control uses a large number of DSSC modules controlled as a group to realize active control of power flow. The DSSC can be used to either increase or decrease the effective line impedance, allowing current to be “pushed” away from or “pulled” into a transmission line. The DSSC concept overcomes some of the most serious limitations of FACTS devices, and points the way to a new approach for achieving power flow control—the use of Distributed FACTS or D-FACTS devices.

II. POWER FLOW CONTROL

FACTS devices are typically high-power high-voltage power converters, operating at 138–500 kV and 10–300 MVA, that are used to control power flow in the transmission and distribution network. For controlling power flow on transmission lines, the series elements clearly have the highest potential and impact. The real and reactive power flow, P and Q , along a transmission line connecting two voltage buses is governed by the two voltage magnitudes V_1 and V_2 and the voltage phase angle difference,

$$\delta = (\delta_1 - \delta_2) \text{ as}$$

$$P_{12} = \frac{V_1 V_2 \sin \delta}{X_L} \tag{1}$$

and

$$Q_{12} = \frac{V_1^2 - V_1 V_2 \cos \delta}{X_L} \tag{2}$$

where X_L is the impedance of the line, assumed to be purely inductive. A series compensator is typically used to increase or decrease the effective reactive impedance of the line, thus allowing control of real power flow between the two buses. D-FACTS devices can be made to communicate wirelessly by receiving commands for impedance injection changes.

The impedance change can be effected by series injection of a passive capacitive or inductive element in the line. Alternatively, a static inverter can be used to realize a controllable active loss-less element such as a negative or positive inductor or a synchronous fundamental voltage that is orthogonal to the line current [6,7]. In the latter case, the power flow depends on the injected quadrature voltage V_q as

$$P_{12} = \frac{V_1 V_2 \sin \delta}{X_L} - \frac{V_1 V_q \cos(\delta/2)}{X_L} \times \left[\frac{\sin(\delta/2)}{\sqrt{\left(\frac{v_1 + v_2}{2v_2}\right)^2 - \frac{v_1}{v_2} \cos^2(\delta/2)}} \right] \tag{3}$$

and the bracketed term is unity if $V_1=V_2=V$. Fig. 1 shows, for equal bus voltage magnitudes, the variation of power flow along a transmission line that can be achieved by injecting passive impedance or an active impedance [1].

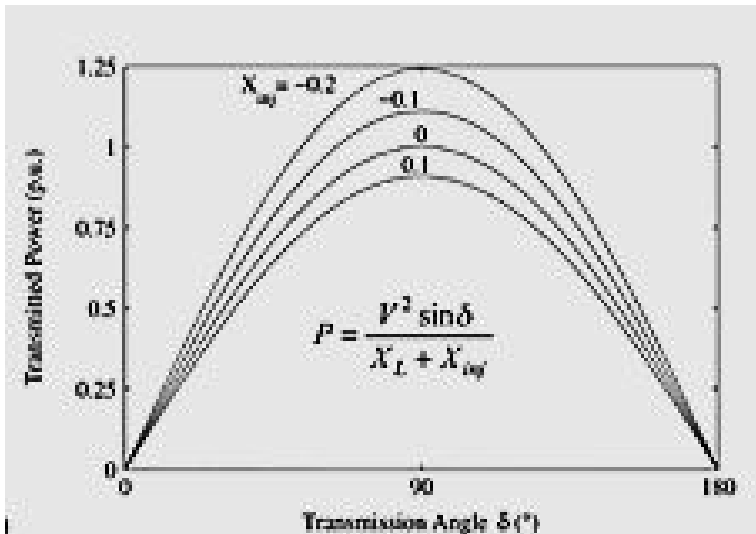

Figure 1: Passive impedance injection as p.u. of X_L (TCSC).

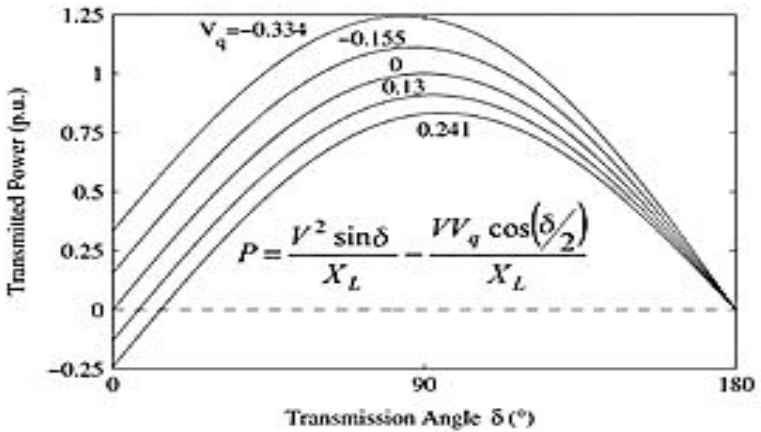

Figure 2: Quadrature voltage injection to achieve active impedance injection

III. CONTROL POTENTIAL OF D-FACTS DEVICES

D-FACTS devices control of one line affects the flows on all lines. The impact that the control of one line flow has on other line flows is specific to the system. If a system has only one loop, the flows are completely coupled and cannot be controlled independently. For any power system, it is useful to be able to determine the control potential available from D-FACTS devices. Analysis of the control of power systems with FACTS devices [12-14] has been examined, but primarily with respect to transient stability, where FACTS devices can be used for control of certain modes of the system. In this work, we are interested in the ability of D-FACTS devices to provide control over line flows throughout the system. When effective line impedances change, power flows redistribute in the system. Our perspective is to show through steady-state analysis the ability of D-FACTS devices to control the way power flows distribute throughout the system.

3.1 Identification of Independently Controllable Line Flows

In some scenarios, it may be clear, which lines need to be targeted for control. The need to operate the system securely is costly but crucial. D-FACTS devices can be used to relieve a

known overloaded element such as a line or transformer. The ability to relieve an overloaded element through the use of D-FACTS control is by itself a strong advantage. Since an overloaded line or transformer can prevent many power transfers from being able to take place, reducing the flow through the overloaded element by even a few percent improves the operation of the power grid. From a broader perspective, D-FACTS devices can be used throughout the system to provide the most comprehensive control. In order to provide the most complete and effective control for the entire system, it is necessary to identify how the control of line flows are related to each other. The coupling of the control of line flows is important to understand so that money and control effort are not wasted in attempts to independently control line flows which are highly coupled.

The following matrices show trivial cases where controls of line flows are completely decoupled (a) and decoupled (b):

a. $x_1 \quad x_2 \quad x_3$ b. $x_1 \quad x_2 \quad x_3$

$$\begin{matrix}
 p_{fl,1} & \begin{bmatrix} 1 & 0 & 0 \\ 0 & 2 & 0 \\ 0 & 0 & 1 \end{bmatrix} \\
 p_{fl,2} & \\
 p_{fl,3} &
 \end{matrix}
 \qquad
 \begin{matrix}
 p_{fl,1} & \begin{bmatrix} 1 & 1 & 1 \\ 2 & 2 & 2 \\ 1 & 1 & 1 \end{bmatrix} \\
 p_{fl,2} & \\
 p_{fl,3} &
 \end{matrix}$$

In the completely decoupled case, the vectors are orthogonal and the angle between them is exactly 90 degrees. In the completely coupled case, the row vectors are perfectly aligned and the angle between them is exactly zero degrees. When the row vectors are perfectly aligned but point in opposite directions, the angle between them is 180 degrees, but they are still completely coupled. Thus, coupling can be determined by comparing the cosine of angles of vectors [15].

The cosine of the angle between two row vectors v1 and v2

$$\cos \theta_{v_1 v_2} = \frac{v_1 \cdot v_2}{\|v_1\| \|v_2\|} \tag{4}$$

of the total power flow to impedance sensitivity matrix $\Sigma \cdot \Phi + \Gamma$ will be called the coupling index. The coupling index has values between -1 and 1. When the coupling index has an absolute value of 1, there is complete correlation, either positive or negative, between the ways the two line flows respond to D-FACTS control. When the coupling index is zero, the line flows have the ability to be controlled independently.

3.2 Identification of Effective D FACTS Locations.

D-FACTS devices are unique because they are well-suited to be placed at multiple locations in the system where their use could be the most beneficial. Comparatively, if only one FACTS device is used, all support goes to the same place. However, reactive power support is most effective locally. Sensitivities can be used to identify lines with a high impact for particular applications. Lines with higher sensitivities are able to provide more control, whereas lines with sensitivities of zero have no impact. The locations for D-FACTS devices are found by determining the lines with the highest sensitivities for the objective. This

approach to system implementation has resulted in large and complex converter installations and barriers that have, so far, limited the commercial success of FACTS technology.

These include:

- High-cost resulting from device complexity and component requirements;
- Single point of failure can cause the entire system to shut down;
- Maintenance and on-site repair requirements for a complex

Custom-engineered system adds significantly to system operating cost and increases mean time to repair (MTTR);

- Lumped nature of system and initial over-rating of devices to accommodate future growth provides poor return on investment (ROI);
- Custom engineered nature of system results in long design and build cycles, resulting in high system cost that will not easily scale down with volume. These limitations are overcome by our proposed D-FACTS system.

IV. TRANSMISSION LINE POWER FLOW CONTROL

Once appropriate lines are targeted for control and effective locations for D-FACTS devices are selected, the problem of power flow control needs to be solved. The goal of the problem can be stated as a desire to attain specified line flows on any number of independently controllable lines through the control of line impedance settings of D-FACTS devices on a specified number of lines.

It is not always possible to achieve a specified power flow on a line, so the line flow control equation,

$$P_{flow,calc}(x) = P_{flow,spec}(x) \tag{5}$$

does not always have a solution. This is acceptable because line flow control is merely an additional benefit. The level of importance of a solution of the power balance equations is much higher than the line flow control equations. For any power system application, the power balance equations $f(p,q)$ must always be satisfied, but if some control over the power flow on a line can be achieved, that can be done as well.

Optimization methods are useful for problems that do not have a solution [16]. The line flow control problem can be examined in an optimization framework which reflects the intuition behind what is being accomplished with D-FACTS devices. The objective is to choose D-FACTS line impedance settings to minimize the differences between the actual power flows and the desired power flows. The objective function is f_0 , where L is the number of line flows to be controlled:

$$f_0 = \sum_{i=1}^L [P_{flow,calc}(x) - P_{flow,spec}(x)]_i^2 \tag{6}$$

The line flow control problem may be stated as follows:

$$\begin{aligned} \min f_0 \\ \text{st } (p,q) (S(\theta,V)) = 0 \end{aligned} \tag{7}$$

$$x \leq x_{max}$$

$$x \geq x_{min}$$

The first constraint of (4) represents the AC power balance equations. The next two constraints are constraints on how much D-FACTS devices are able to change the line impedances. The gradient of f_0 is given by the following,

$$\nabla f_0 = 2(A'x) \tag{8}$$

where the matrix A' is formed from elements of the power flow to impedance total sensitivity matrix, $\Sigma \cdot \Phi + \Gamma$. Thus, D-FACTS devices are able to control line flows on any lines with high enough sensitivities, not just their own line. Important connections exist between sensitivities and optimization theory [17], [18]. The sensitivities which determine independently controllable line flows and effective D-FACTS locations also exactly provide the gradient needed to solve (15) using steepest descent. Steepest descent steps are given by the following, where α is a positive, scalar step size:

$$x^{v+1} = x^v - \alpha \nabla f_0 \tag{9}$$

Knowledge of the total sensitivity of an equation to the control variables is enough to know how to minimize that function. Minimizing the objective function is equivalent to controlling real power line flows with D-FACTS devices.

V. D-FACTS CONTROL FOR A GENERAL PROBLEM

The same control approach is extended to other power system problems as follows

$$\begin{aligned} \min f_2(s_{(\theta, \nu)}, x) \\ s_{(p)}(s_{(,)}) = 0 \\ x \leq x_{max} \\ x \geq x_{min} \end{aligned} \tag{10}$$

where f_2 is the objective function for the problem of interest and D-FACTS devices are placed at locations in the system determined by the sensitivities of the objective function f_2 to line impedance which are furthest from zero.

The direction of steepest descent is given by $-\nabla f_2$, where ∇f_2 is the total derivative of the objective function with respect to x . Line impedance settings to minimize f_2 are

$$x^{v+1} = x^v - \alpha \cdot \nabla f_2 \tag{11}$$

where α is a positive, scalar step size. D-FACTS devices may then implement the final line impedance settings. This approach can be used to implement D-FACTS applications such as loss minimization and voltage control.

5.1 Loss Minimization and Voltage Control.

For loss minimization, if f_2 is the losses, the total sensitivity to line impedances is given by $\nabla f_2 = K$. For voltage control including both raising and lowering system voltages, f_2 is the sum of the differences of the bus voltages from specified values. The gradient ∇f_2 , is given by $\nabla f_2 = 2\eta(x) \Phi_v$ where Φ_v , the sensitivities of voltages with respect to line impedance, are the lower section of the state to impedance sensitivity matrix, $\Phi = [\Phi_\theta, \Phi_v]^T$.

5.2 Comments on Other Solution Methods.

The steepest descent optimization approach is a logical choice because it requires only knowledge of the sensitivities and the ability to solve the power flow, and it guarantees movement toward the optimum. The ability to guarantee descent is important since the goal is to determine the extent of D-FACTS abilities. One approach, often using Newton’s method, treats the effective reactance of D-FACTS devices as state variables and solves the modified power flow equations for the line impedances in addition to the other state variables. Problems include that Newton’s method does not guarantee descent, may not converge, and may not exhibit expected behavior if started far from the solution. If second order sensitivities can be calculated or approximated, the class of Newton-like methods [18] may be worthwhile to investigate. Newton-like methods also alleviate some of the problems with pure Newton’s method.

VI. SCHEMATIC & SIMULATION DIAGRAM

A controlled transmission system can be made up of a large number, of DSSC modules, each module containing a small rated single phase inverter, a communications link and a single turn transformer (STT) that is mechanically clamped on to—and suspended from—the transmission line conductor.

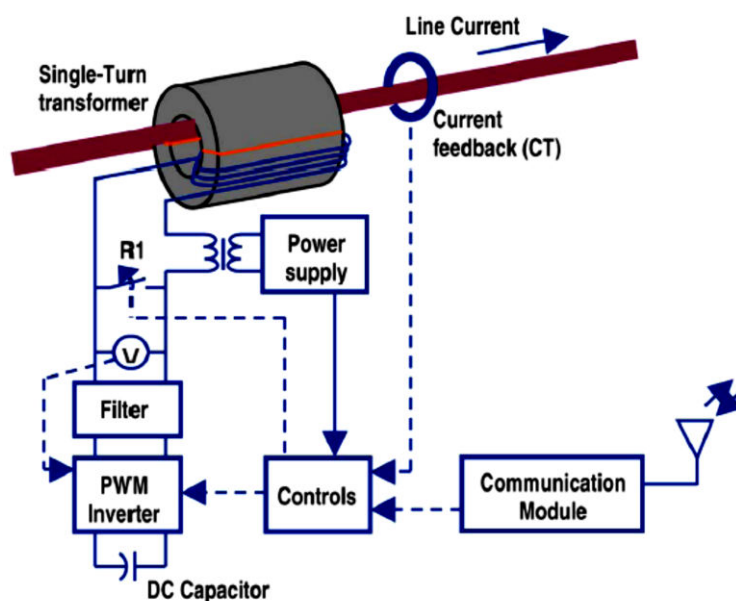

Figure 3: Schematic power circuit.

The STT (single turn transformer) uses the transmission conductor as a secondary winding, directly injecting the desired voltage into the cable itself. The inverter is self-powered by induction from the line, and can be controlled to inject a voltage that is orthogonal to the line current directly into the conductor. The module can either be suspended from the conductor or configured as a replacement for the conductor support clamp on an insulator. Further, since it does not require supporting phase-ground insulation, the module can easily be applied at any transmission voltage level.

When the transmission line is not powered up, the STT is bypassed by a normally closed relay contact (R1) that opens once control power is available. A current transformer

is used to generate control power, allowing the DSSC module to operate as long as the line current is greater than a minimum level. The line appears to the inverter as an inductive current source. The single phase inverter uses four IGBT devices along with an output LC filter and a dc bus capacitance. The inverter output voltage is controlled using pulse width modulation techniques, and has two components. The first is in quadrature with the line current, and represents the desired impedance to be injected. The second is in phase with the line current, and allows compensation of power losses in the inverter, and regulation of the dc bus of the inverter. System commands for gradual changes are received from a central control center using a wireless or power line communication (PLC) technique.

The STT is a key component of the DSSC module. It is designed such that the module can be clamped onto an existing transmission line. The inverters present clearly demonstrate that the semiconductors and components used are commercially available in very high volumes for the motor drives, UPS, and automotive industries, thus validating the potential for realizing low cost.

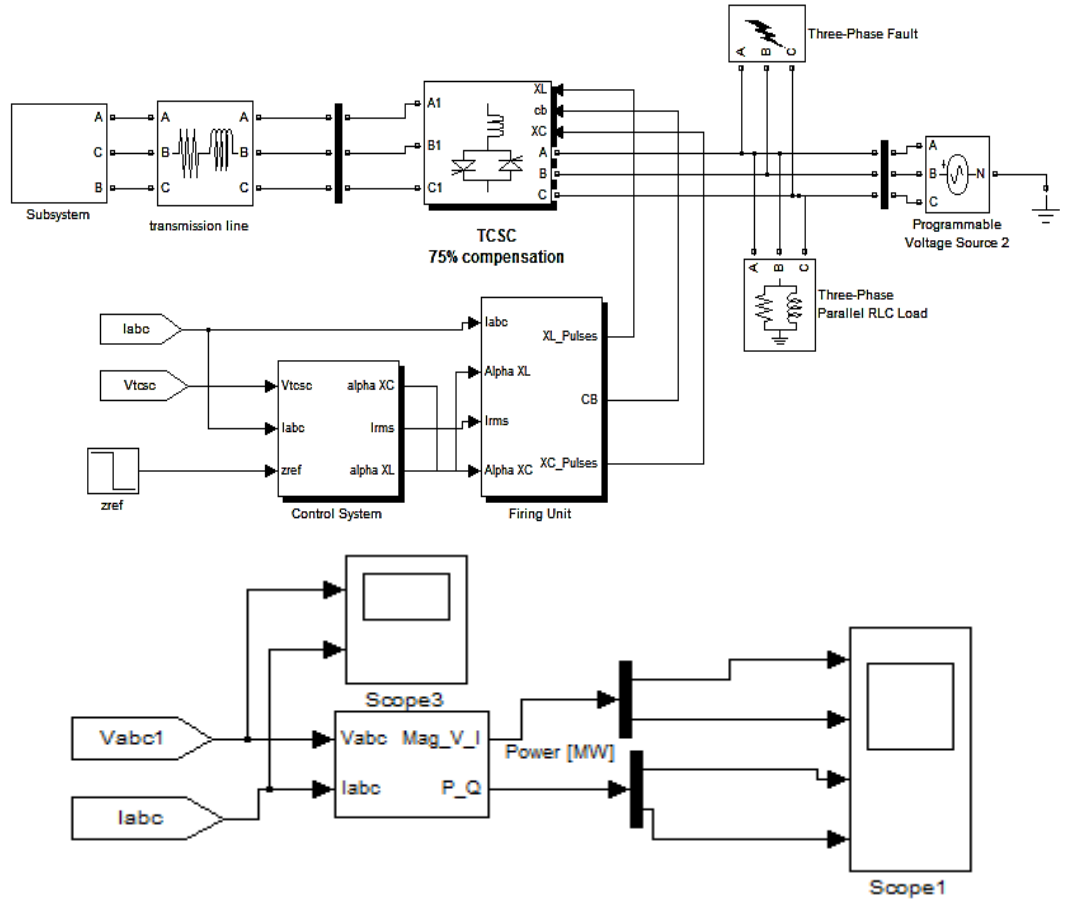

Figure 4: Simulation Diagram

The above figure shows the simulation diagram for three phase system in a transmission line which is given to the TCSC which gives 75% compensation. Now the TCSC is analyzed with any type of fault such as Line to phase or phase to line or phase to phase etc.

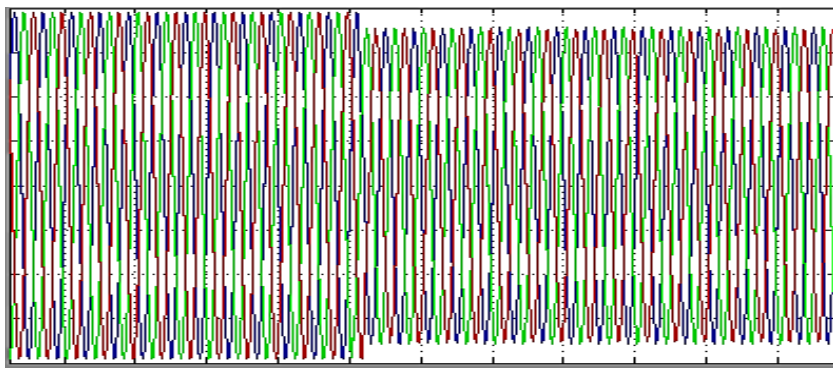

Figure 5: Voltage sag due to fault

The above figure shows the voltage output and the sag present in the output and this can be compensated using TCSC in our circuit. In the same manner the other types of faults can also be analyzed and the output can be obtained by reducing faults of any type.

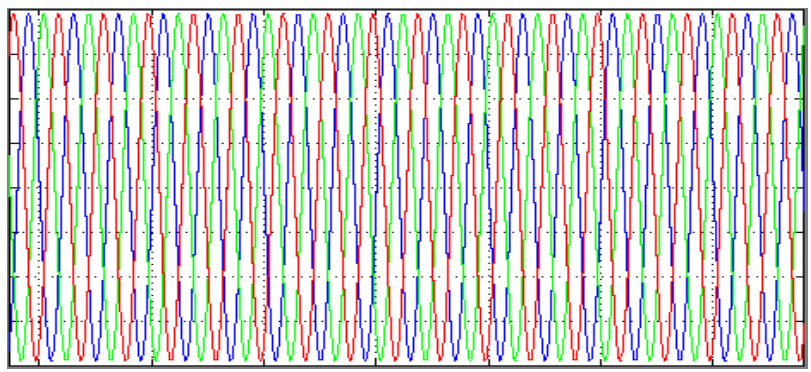

Figure 6: Voltage after compensation

The above figure shows the voltage output by using TCSC in which the voltage is compensated by 75% and the sag is removed thereby the performance of the system is improved.

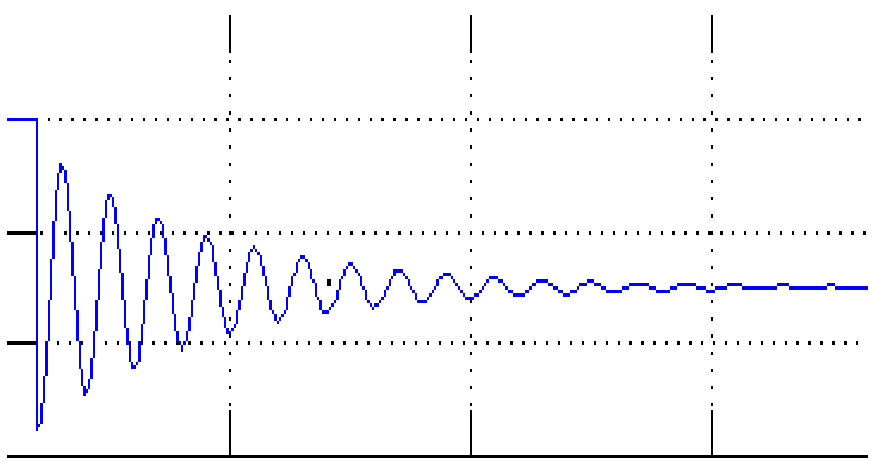

Figure 7: Active Power

The Active power output for the proposed system is given in the above figure.

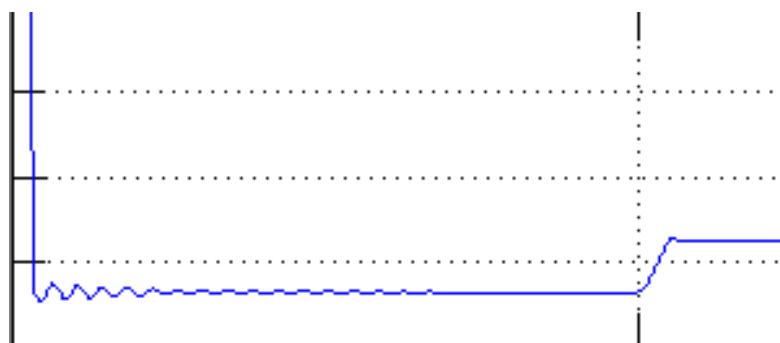

Figure 8: Reactive Power

The reactive power output is given for the proposed system is given in the above figure. This can also be further reduced in future.

VII. CONCLUSION

D-FACTS devices have the unique ability to be incrementally installed on multiple lines throughout a system to provide power flow control wherever needed. Effective D-FACTS device locations and independently controllable flows can be identified from sensitivities. After D-FACTS devices are installed in certain fixed locations, their control objective can easily be changed to target other lines flows.

Thus, D-FACTS devices can provide widespread, versatile control for power systems. In this paper, the successful control of line flows with D-FACTS devices is presented for two test systems. A general approach for line flow control with D-FACTS devices is developed. The use of sensitivities in solving nonlinear problems can be extrapolated to any application of interest and for any system given.

A controlled transmission line implemented with multiple DSSC modules can realize significant benefits at a system level. At the highest level, it can:

- enhance asset utilization;
- reduce system congestion;
- Increase available transfer capacity (ATC) of the system; thus by using this system the faults present can be minimized as well as compensated.

VIII. REFERENCES

- [1] FACTS Working Group, "Proposed Terms and Definitions for Flexible AC Transmission System (FACTS)", *IEEE Transactions on Power Delivery*, Vol. 12, Issue 4, October 1997, p 1848-1853.
- [2] P. Hassink, D. Matthews, R. O'Keefe, F. Howell, S. Arabi, C. Edwards, E. Camm, "Dynamic Reactive Compensation System for Wind Generation Hub," *IEEE PES Power Systems Conference and Exposition*, 2006, p 440-445.
- [3] D. Divan, "Improving Power Line Utilization and Performance With D-FACTS Devices," *IEEE PES General Meeting*, June 2005, p 2419 - 2424.
- [4] D. M. Divan, W. E. Brumsickle, R. S. Schneider, B. Kranz, R. W. Gascoigne, D. T. Bradshaw, M. R. Ingram, I. S. Grant, "A Distributed Static Series Compensator System for Realizing Active Power Flow Control on Existing Power Lines," *IEEE Transactions on Power Delivery*, Vol. 22, No. 1, Jan 2007, p 642 - 649.
- [5] H. Johal, D. Divan, "Design Considerations for Series-Connected Distributed FACTS Converters," *IEEE Transactions on Industry Applications*, Vol. 43, No. 6, Nov/Dec 2007, p 654 - 661.

- [6] D. G. Ramey, R. J. Nelson, J. Bian, T. A. Lemak, "Use of FACTS Power Flow Controllers to Enhance Transmission Transfer Limits," *Proceedings of the American Power Conference*, 1994, p 712-718.
- [7] L. Gyugyi, C. D. Schauder, K. K. Sen, "Static Synchronous Series Compensator: A Solid-State Approach to the Series Compensation of Transmission Lines," *IEEE Transactions on Power Delivery*, Vol. 12, No. 1, Jan. 1997, p 406 - 417.
- [8] L. Gyugyi, C. D. Schauder, S. L. Williams, T. R. Rietman, D. R. Torgerson, A. Edris, "The Unified Power Flow Controller: A New Approach to Power Transmission Control," *IEEE Transactions on Power Delivery*, Vol. 10, No. 2, Apr. 1995, p 1085 - 1097.
- [9] L. Gyugyi, "Dynamic Compensation of AC Transmission Lines by Solid-State Synchronous Voltage Sources," *IEEE Transactions on Power Delivery*, Vol. 9, No. 2, Apr. 1994, p 904 - 911.
- [10] O. Alsac, J. Bright, M. Prais, B. Stott, "Further Developments in LP- Based Optimal Power Flow," *IEEE Transactions on Power Systems*, Vol. 5, No. 3, Aug 1990, p 697 - 711.
- [11] W. F. Tinney, V. Brandwajn, S.M. Chan, "Sparse Vector Methods," *IEEE Transactions on Power Apparatus and Systems*, Vol. PAS- 104, No. 2, Feb 1985, 295 - 301.
- [12] X. R. Chen, N. C. Pahalawaththa, U. D. Annakkage, C. S. Kumble, "Controlled series compensation for improving the stability of multi- machine power systems," *IEE Proceedings: Generation, Transmission and Distribution*, v 142, n 4, Jul, 1995, p 361-366.
- [13] H. Okamoto, A. Kurita, Y. Sekine, "A method for identification of effective locations of variable impedance apparatus on enhancement of steady-state stability in large scale power systems," *IEEE Transactions on Power Systems*, v 10, n 3, Aug. 1995, p 1401-7.
- [14] X. R. Chen, N. C. Pahalawaththa, U. D. Annakkage, C. S. Kumble, "Output feedback TCSC controllers to improve damping of meshed multi-machine power systems," *IEE Proceedings: Generation, Transmission and Distribution*, v 144, n 3, May, 1997, p 243-248.
- [15] A. M. A. Hamdan, A. M. Elabdalla, "Geometric Measures of Modal Controllability and Observability of Power System Models," *Electric Power Systems Research*, v 15, n 2, Oct 1988, p 147-155.
- [16] T. J. Overbye, "A Power Flow Measure for Unsolvable Cases," *IEEE Transactions on Power Systems*, Vol. 9, No. 3, Aug 1994, p 1359-1365.
- [17] D. G. Luenberger, *Linear and Nonlinear Programming*, 2nded, Kluwer Academic Publishers Group, 2003. [18] D. P. Bertsekas, *Nonlinear Programming*, 2nd ed, Massachusetts: Athena Scientific, 1999.

To Cite This Article

Baby,M. , Jacob,S. (2016): "Power Flow Control In A Transmission Line Using D-Facts Devices" *International Journal of Informative & Futuristic Research (ISSN: 2347-1697)*, Vol. 4 No. (4), December 2016, pp. 5779-57899, Paper ID: IJIFR/V4/E4/013.

WOMEN EMPOWERMENT THROUGH MICRO FINANCE

Paper ID

IJIFR/V4/ E4/ 014

Page No.

5790-5795

Subject Area

Commerce

Keywords

Women Empowerment, Micro Finance, SHGs, Finance

P. N. Mohamed Inzamam Ul Haq

Research Scholar
Department of Commerce
V. O. Chidambaram College
Tuticorin-Tamilnadu

Abstract

Microfinance is emerging as a powerful instrument for poverty alleviation in the new economy. In India, Microfinance scene is dominated by Self Help Group (SHGs)-Bank Linkage Programme as a cost effective mechanism for providing financial services to the "Unreached Poor" which has been successful not only in meeting financial needs of the rural poor women but also strengthen collective self-help capacities of the poor, leading to their empowerment. Economic empowerment results in women's ability to influence or make decision, increased self-confidence, better status and role in household etc. Micro finance is necessary to overcome exploitation, create confidence for economic self-reliance of the rural poor, particularly among rural women who are mostly invisible in the social structure. This paper puts forward how micro finance has received extensive recognition as a strategy for economic empowerment of women. An effort is also made to suggest the ways to increase women empowerment.

I. INTRODUCTION

Empowerment implies expansion of assets and capabilities of people to influence control and hold accountable institution that affects their lives (World Bank Resource Book). Empowerment is the process of enabling or authorizing an individual to think, to behave, to take action and to control work in an autonomous way. It is the state of feelings of self-empowered to take control of one's own destiny. It includes both controls over resources (Physical, Human, Intellectual and Financial) and over ideology (Belief, values and attitudes) (Batliwala, 1994). Empowerment is a multi-dimensional social process that helps people gain control over their own lives communities and in their society, by acting on issues that they define as important. Empowerment occurs within sociological psychological economic spheres and at various levels, such as individual, group and community and



challenges our assumptions about status quo, asymmetrical power relationship and social dynamics. Empowering women puts the spotlight on education and employment which are an essential element to sustainable development.

2. EMPOWERMENT: FOCUS ON WOMEN

In India, the trickle down effects of macroeconomic policies have failed to resolve the problem of gender inequality. Women have been the vulnerable section of society and constitute a sizeable segment of the poverty-struck population. Women face gender specific barriers to access education health, employment etc. Micro finance deals with women below the poverty line. Micro loans are available solely and entirely to this target group of women. There are several reason for this: Among the poor , the poor women are most disadvantaged –they are characterized by lack of education and access of resources, both of which is required to help them work their way out of poverty and for upward economic and social mobility. The problem is more acute for women in countries like India, despite the fact that women’s labour makes a critical contribution to the economy. This is due to the low social status and lack of access to key resources. Evidence shows that groups of women are better customers than men, the better managers of resources. Since women’s empowerment is the key to socio economic development of the community; bringing women into the mainstream of national development has been a major concern of government. The ministry of rural development has special components for women in its programmes. Funds are earmarked as “Women’s component” to ensure flow of adequate resources for the same. Besides Swarnagayanti Grameen Swarazgar Yojona (SGSY), Ministry of Rural Development is implementing other scheme having women’s component .They are the Indira Awas Yojona (IAJ), National Social Assistance Programme (NSAP), Restructured Rural Sanitation Programme, Accelerated Rural Water Supply programme (ARWSP) the (erstwhile) Integrated Rural Development Programme (IRDP), the (erstwhile) Development of Women and Children in Rural Areas (DWCRA) and the Jowahar Rozgar Yojana (JRY).

3. CONCEPT AND FEATURES OF MICRO FINANCE

The term micro finance is of recent origin and is commonly used in addressing issues related to poverty alleviation, financial support to micro entrepreneurs, gender development etc. There is, however, no statutory definition of micro finance. The taskforce on supportive policy and Regulatory Framework for Microfinance has defined microfinance as “Provision of thrift, credit and other financial services and products of very small amounts to the poor in rural, semi-urban or urban areas for enabling them to raise their income levels and improve living standards”. The term “Micro” literally means “small”. But the task force has not defined any amount. However as per Micro Credit Special Cell of the Reserve Bank Of India, the borrowable amounts the limit of Rs.25000/- could be considered as micro credit products and this amount could be gradually increased up to Rs.40000/- over a period of time which roughly equals to 500\$ – a standard for South Asia as per international perceptions.

The term micro finance sometimes is used interchangeably with the term micro credit. However while micro credit refers to purveyance of loans in small quantities, the term microfinance The word “Microfinance” terms as banking through groups. The essential features of the approach are to provide financial services through the groups of individuals, formed either in joint liability or co-obligation mode.

The other dimensions of the microfinance approach are:

- Savings/Thrift precedes credit
- Credit is linked with savings/thrift
- Absence of subsidies
- Group plays an important role in credit appraisal, monitoring and recovery.

Basically groups can be of two types:

Self Help Groups (SHGs): The group in this case does financial intermediation on behalf of the formal institution. This is the predominant model followed in India.

Grameen Groups: In this model, financial assistance is provided to the individual in a group by the formal institution on the strength of group’s assurance. In other words, individual loans are provided on the strength of joint liability/co obligation. This microfinance model was initiated by Bangladesh Grameen Bank and is being used by some of the Micro Finance Institutions (MFIs) in our country.

IV. WOMEN EMPOWERMENT AND MICRO FINANCE: DIFFERENT PARADIGMS

Concern with women’s access to credit and assumptions about contributions to women’s empowerment are not new. From the early 1970s women’s movements in a number of countries became increasingly interested in the degree to which women were able to access poverty-focused credit programmes and credit cooperatives. In India organizations like Self-Employed Women’s Association (SEWA) among others with origins and affiliations in the Indian labour and women’s movements identified credit as a major constraint in their work with informal sector women workers. The problem of women’s access to credit was given particular emphasis at the first International Women’s Conference in Mexico in 1975 as part of the emerging awareness of the importance of women’s productive role both for national economies, and for women’s rights. This led to the setting up of the Women’s World Banking network and production of manuals for women's credit provision. From the mid-1980s there was a mushrooming of donor, government and NGO-sponsored credit programmes in the wake of the 1985 Nairobi women’s conference (Mayoux, 1995a). The 1980s and 1990s also saw development and rapid expansion of large minimalist poverty-targeted micro-finance institutions and networks like Grameen Bank, ACCION and Finca among others. In these organizations and others evidence of significantly higher female repayment rates led to increasing emphasis on targeting women as an efficiency strategy to increase credit recovery. A number of donors also saw female-targeted financially-sustainable micro-finance as a means of marrying internal demands for increased efficiency because of declining budgets with demands of the increasingly vocal gender lobbies. The trend was further reinforced by the Micro Credit Summit Campaign starting in 1997 which

had 'reaching and empowering women' as its second key goal after poverty reduction (RESULTS 1997).

V. MICRO FINANCE: INSTRUMENT FOR WOMEN EMPOWERMENT

Micro Finance is emerging as a powerful instrument for poverty alleviation in the new economy. In India, micro finance scene is dominated by Self Help Groups (SHGs) – Bank Linkage Programme, aimed at providing a cost effective mechanism for providing financial services to the “unreached poor”. Based on the philosophy of peer pressure and group savings as collateral substitute, the SHG programme has been successful in not only in meeting peculiar needs of the rural poor, but also in strengthening collective self-help capacities of the poor at the local level, leading to their empowerment. Micro Finance for the poor and women has received extensive recognition as a strategy for poverty reduction and for economic empowerment. Increasingly in the last five years, there is questioning of whether micro credit is most effective approach to economic empowerment of poorest and, among them, women in particular. Development practitioners in India and developing countries often argue that the exaggerated focus on micro finance as a solution for the poor has led to neglect by the state and public institutions in addressing employment and livelihood needs of the poor. Credit for empowerment is about organizing people, particularly around credit and building capacities to manage money. The focus is on getting the poor to mobilize their own funds, building their capacities and empowering them to leverage external credit. Perception women is that learning to manage money and rotate funds builds women’s capacities and confidence to intervene in local governance beyond the limited goals of ensuring access to credit. Before 1990’s, credit schemes for rural women were almost negligible. The concept of women’s credit was born on the insistence by women oriented studies that highlighted the discrimination and struggle of women in having the access of credit. However, there is a perceptible gap in financing genuine credit needs of the poor especially women in the rural sector. There are certain misconception about the poor people that they need loan at subsidized rate of interest on soft terms, they lack education, skill, capacity to save, credit worthiness and therefore are not bankable. Nevertheless, the experience of several SHGs reveals that rural poor are actually efficient managers of credit and finance. Availability of timely and adequate credit is essential for them to undertake any economic activity rather than credit subsidy.

6. PROBLEMS AND CHALLENGES

Surveys have shown that many elements contribute to make it more difficult for women empowerment through micro businesses. These elements are:

- Lack of knowledge of the market and potential profitability, thus making the choice of business difficult.
- Inadequate book-keeping.
- Employment of too many relatives which increases social pressure to share benefits.
- Setting prices arbitrarily.
- Lack of capital.

- High interest rates.
- Inventory and inflation accounting is never undertaken.
- Credit policies that can gradually ruin their business (many customers cannot pay cash; on the other hand, suppliers are very harsh towards women).

Other shortcomings includes,

1. **Burden of meeting:** Time consuming meetings, in particular in programmes based on group lending, and time consuming income generating activities without reduction of traditional responsibilities increase women's work and time burden.
2. **New Pressures:** By using social capital, in-group lending/group collateral programmes, additional stresses and pressures are introduced, which might increase vulnerability and reflect disempowerment.
3. **Reinforcement of traditional gender roles:** lack of economic empowerment: Micro finance assists women to perform traditional roles better and women thus remain trapped in low productivity sectors, not moving from the group of survival enterprises to micro-enterprises. There is evidence of men withdrawing their contributions to certain types of household expenditures.

VII. CONCLUSION AND SUGGESTION

Numerous traditional and informal system of credit that was already in existence before micro finance came into vogue. Viability of micro finance needs to be understood from a dimension that is far broader- in looking at its long-term aspects too .very little attention has been given to empowerment questions or ways in which both empowerment and sustainability aims may be accommodated. Failure to take into account impact on income also has potentially adverse implications for both repayment and outreach, and hence also for financial sustainability. An effort is made here to present some of these aspects to complete the picture. A conclusion that emerges from this account is that micro finance can contribute to solving the problems of inadequate housing and urban services as an integral part of poverty alleviation programmes. The challenge lies in finding the level of flexibility in the credit instrument that could make it match the multiple credit requirements of the low income borrower without imposing unbearably high cost of monitoring its end use upon the lenders. A promising solution is to provide multipurpose lone or composite credit for income generation, housing improvement and consumption support. Consumption loan is found to be especially important during the gestation period between commencing a new economic activity and deriving positive income. Careful research on demand for financing and savings behaviour of the potential borrowers and their participation in determining the mix of multi-purpose loans are essential in making the concept work. The organizations involved in micro credit initiatives should take account of the fact that:

- Credit is important for development but cannot by itself enable very poor women to overcome their poverty.
- Making credit available to women does not automatically mean they have control over its use and over any income they might generate from micro enterprises.

- In situations of chronic poverty it is more important to provide saving services than to offer credit.
- A useful indicator of the tangible impact of micro credit schemes is the number of additional proposals and demands presented by local villagers to public authorities.

Nevertheless ensuring that the micro-finance sector continues to move forward in relation to gender equality and women's empowerment will require a long-term strategic process of the same order as the one in relation to poverty if gender is not to continue to 'evaporate' in a combination of complacency and resistance within donor agencies and the micro-finance sector. India is the country where a collaborative model between banks, NGOs, MFIs and Women's organizations is furthest advanced. It therefore serves as a good starting point to look at what we know so far about 'Best Practice' in relation to micro-finance for women's empowerment and how different institutions can work together.

It is clear that gender strategies in micro finance need to look beyond just increasing women's access to savings and credit and organizing self help groups to look strategically at how programmes can actively promote gender equality and women's empowerment. Moreover the focus should be on developing a diversified micro finance sector where different type of organizations, NGO, MFIs and formal sector banks all should have gender policies adapted to the needs of their particular target groups/institutional roles and capacities and collaborate and work together to make a significant contribution to gender equality and pro-poor development.

VIII. REFERENCES

- [1] Fisher, Thomas and M.S. Sriram ed., 2002, Beyond Micro-credit: Putting Development Back into Microfinance, New Delhi: Vistaar Publications; Oxford: Oxfam.
- [2] Harper, Malcolm, 2002, "Promotion of Self Help Groups under the SHG Bank Linkage Program in India", Paper presented at the Seminar on SHG-bank Linkage Programme at New Delhi, November 25-26, 2002.
- [3] Kabeer N (2001), "Conflicts Over Credit: Re-evaluation the Empowerment Potential of Loans to Women in Rural Bangladesh": World Development, Vol.29, No.1.
- [4] Mayoux, L. 1998. Women's Empowerment and Micro-finance programmes: Approaches, Evidence and Ways Forward. The Open University Working Paper No 41.
- [5] Ackerley, B. (1995). In "Testing the Tools of Development: Credit programmes, Loan Involvement and Women's Empowerment, World Development 26(3), 56-68".

To Cite This Article

P. N. Mohamed Inzamam Ul Haq (2016): "Women Empowerment Through Micro Finance" *International Journal of Informative & Futuristic Research (ISSN: 2347-1697)*, Vol. 4 No. (4), December 2016, pp. 5790-5795, Paper ID: IJIFR/V4/E4/014.

THE DEFECTS IN THE EVALUATION SYSTEM IN TEACHING ENGLISH LANGUAGE

Paper ID

IJIFR/V4/ E4/ 016

Page No.

5796-5800

Subject Area

English

Keywords

Evaluation System, Teaching English, Defects, Diagnosis, Rectification

Dr. S. Raja Soundara Pandian

Assistant Professor
Department of Education (English)
Government College of Education
Orathanad - Tamilnadu, India

Abstract

India, a country of diversity enjoys unity by means of English, the international language and the political constitution, the two assets gifted by Great Britain. Defects in evaluation spoil the learning of the language. Evaluation should be like complete scanning of the body along all physical measurements including strength and appearance. Examination is like a simple diagnosis for treatment. Annual Examination is promotion oriented and public examinations are meant for testing the eligibility for higher studies. Passing the examinations is not the aim of learning and learning English. Evaluation should be utilized for improving learning and teaching processes.

I. INTRODUCTION

When our country India attained freedom and established the democratic form of government it was deplorable in education and economy. Ten percent of population was able to sign, though with difficulty, had a square meal daily and a pair of minimum clothing. Within a short period of sixty years, India has achieved the status of a mighty power with scientific advancement and ability to feed decently one sixth of world's population and provide them with modern amenities. It is due to the language English and the constitution in the British model. English gives us the unifying force in spite of diversity in culture and parochial views of the states formed on the basis of language.

We Indians should realize the indispensability of English. To respond with 'Yes' or 'No', the servants or attendees should be able to understand English. To express difficulties and requirements or to convey the message to others basic knowledge of English is needed. To study professional courses or to become executives or to take up white-collar jobs, a good command in English both in speaking and writing is a must. The reason explained above makes us realize the truth that the correct method of teaching English paves the way





to enjoy the benefit of knowing English. The Parents show interest first of all in the physical growth of children, so they take measurement of height, weight, chest and hip. Like that improvement of knowledge in English should be tested intermittently. It may be after a time interval or after completion of a lesson or a portion. Mere tests or examinations cannot be accepted as evaluation. Testing is like weighing the vegetables but evaluation is finding the value of jewels judging the purity of gold and appraising the worth of diamonds and pearls. Improvement of students' English knowledge cannot be understood by tests and examinations. In every type of questions there is some defect that cannot be explained in detail in an article of restricted measure of length.

Evaluation without defects is an indicator of students' improvement in English, which helps the teachers to adopt new teaching styles as immediate rectification. So, the defects in evaluation spoil the learning of the language, English which is undergoing universal modernization and decoration with different styles. Evaluation should be like complete scanning of the body and judging the physical strength and appearance. The improvement being profitably attained or absorbed cannot be tested because there are defects in every type of questions cannot be measured with numerical indication of marking system but can be evaluated through analysis, judgment and awarding weightage to the development shown in different areas.

When testing standard is raised to its perfection it becomes evaluation. Systematically formed testing should let the students know their deficiencies in understanding the Thematic and linguistic objectives and in increasing the vocabulary including phrases and idioms. Test is usually held occasionally at the end of the term or end of the year. When it becomes a continuous process calculating the students' improvement at every point of instruction it becomes a defect less evaluation. Teaching and testing should be repeated in this continuous process of repetition for remediation like teaching, testing to know the students' deficiencies, re-teaching or remedial teaching for rectifying the deficiencies. Measurement of acquired knowledge in English cannot be measured in numbers by means of marking system which is subjective. The progress of a particular student can be understood or evaluated by comparing his personal achievement with class average. Mental traits or psychological attitudes are beyond the reach of usual testing and measurements.

II. HOW SHOULD BE A BEST EVALUATION?

Evaluation is an inseparable process of learning and teaching. Evaluation is inevitable and indispensable to diagnose the students' difficulties in learning and to take instant remedial measures in teaching. Gronlund (1981) defines evaluation as "a systematic process of determining the extent to which instructional objectives are achieved by pupils." He describes the process of evaluation as quantitative description or qualitative description or both plus value judgments. Beeby (1977) defines evaluation as "The systematic collection and interpretation of evidence leading to a judgment of value and action." To define evaluation briefly but completely, we can express that it is a continuous and



comprehensive process to gather reliable information about the students by means of effective tools as tests, observation, interview etc., for judging the students' achievement and difficulties to take appropriate remedial measures in the teaching techniques and styles to improve their learning.

III. THE USEFUL ROLE AND FUNCTIONING OF EVALUATION

Chauncey and Dobbin (1968) and Ausubel and Robinson (1969) stress some functions and purposes of evaluation like facilitating learning and teaching, planning and evaluating curriculum, guiding and counseling the students with care and following individually suited instructional methods. If the evaluation structure cannot discover or diagnosis the specific defects in learning of a particular student which helps the teacher take remedial measures, the evaluation process is utterly defective.

According to Tyler (1969) the important components of Educational process are (i) Objectives (ii) learning experiences and (iii) learner appraisal or evaluation. These components are interrelated. Objectives help to determine learning experiences which in turn give ideas and suggestions for learner appraisal. It is learner appraisal that picks up the useful learning experiences that contribute to learning. "Appraisal of the learner leads to the appraisal of curriculum, the teaching styles and techniques, the teacher himself, the institution etc.,"

IV. THE DEFECTIVE EVALUATION SYSTEM

If it does not help for adopting effective instructional methods eliminating unsuccessful ones, for improving the students' performance through continuous and comprehensive evaluation and for allowing the teachers to adopt up to date teaching styles and curriculum changes according to the individual difficulties; the evaluation system should be considered to be ineffective and useless with defects. Annual Examination is promotion oriented and public examination is meant for testing students' eligibility for higher studies. Passing the examinations is not the aim of learning and learning English.

From the feedback data gathered from examinations, the Educational Department does not take up the right evaluation measures from prescribing the curriculum to conducting effective mode of examination. Educational institutions never think of improving the teaching standards. While evaluating students' achievement, the teacher should notice their defects which will evaluate the defects in teaching standards.

V. HOW TO APPLY EVALUATION SYSTEM IN TEACHING ENGLISH

Evaluation is not the event of end of year. Every moment every student should be evaluated from the facial differences in trying to understand what is taught as usual. The teachers' experience should help them providing the power of mind reading which will analyse the students' difficulties. Application of appropriate remedial methods of teaching is followed after successful evaluation. Improvement attained in learning English cannot be evaluated by written examinations. In every form of question types, like multiple choice

questions, matching types, filling the blanks, matching the terms with their meanings, essay type questions etc. there are many defects. Talent in learning a language cannot be tested by a single method since multifaceted acquirement of knowledge is essential for obtaining wholesome success in the four departments namely 'listening and speaking' and 'reading and writing.'

VI. DRAWBACKS FOUND IN EVALUATION IN EVERY LANGUAGE DEPARTMENT

First of all students should listen deeply and continuously without break or wavering for which students' interest and teachers' talented and attractive way of techniques are essential. For teaching other subject matter is to be conveyed but in teaching a language and especially English, pronunciation should be given full weight. Intonation, stress omitting the sounding some letters should be exactly followed by the language teachers of English. For immediate adaptation of a suitable technique, the students should be questioned intermittently to evaluate their speaking with correct pronunciation.

This enlightens the teachers that evaluation should be a separable part of instruction. Listening is the gateway for the entry of knowledge in the brain of the students, which is freely following from the reservoir of teachers' knowledge. The faults of evaluation should be instantly done away with immediate rectification. Next comes speaking, in the delivery of expression through variation in sounding, the air from expiration passing through windpipe get transformed into sounding by means of vocal chords. This sounding gets variation with the combined effort of the palate (soft and hard), the tongue (tip, middle and back), the lips and teeth in accordance with the sounding of the alphabets. Can written examinations evaluate the mistakes found in this process exactly?

Reading and writing of English need the knowledge of basic grammar, special way of structures, specific phraseology and unique application of idioms, the special and extraordinary property of English, the universal language. Speaking and listening are simultaneous occurrences of past, present and future. Writing is done to deliver the message to readers of the contemporary people and for the future generations. Readers should be able to understand the writers' messages.

VII. CONCLUSION

Evaluation is a nonstop process for immediate and instant rectification. So the tests and examinations cannot be considered as evaluation methods. So the process of evaluation followed at present is full of mistakes. Let us try our test to formulate an effective mode of evaluation though not a perfect one.

VIII. SUGGESTION FOR THE FUTURE

Experienced educationists, Educational institutions really working for the improvement of the students and education department of the government engaged in the development of understanding English language, should try their best to formulate an evaluation system which will be beneficial to the future students.

IX. REFERENCES

- [1] Allen, H. B and Campbell, R. N (1977). Teaching English as a second language. New Delhi, TMH.
- [2] Bose, K (1979). Teaching of English – A Modern Approach. New Delhi, Doaba House.
- [3] Chandy, V (1963). The Teaching of English in Schools. Mavelikara, Loyal Press.
- [4] Kohli, A. L (1975). Techniques of Teaching English. New Delhi, Dhanpat Rai.
- [5] Lado, R (1974), Language Teaching. Bombay, TMH.
- [6] Nunan, D (1991). Language Teaching Methodology. London, Prentice Hall.
- [7] Panchal, M. R (1976). Teaching English in India. New Delhi, Light and Life.
- [8] Ryburn, W.M (1963). The Teaching of English in India. Bombay, OUP.

To Cite This Article

Soundara Pandian, R. S. (2016): “The Defects In The Evaluation System In Teaching English Language” *International Journal of Informative & Futuristic Research (ISSN: 2347-1697)*, Vol. 4 No. (4), December 2016, pp. 5796-5800, Paper ID: IJIFR/V4/E4/016.

A SKETCH OUT ON TRANSGENDER : EDUCATIONAL INSIGHTS

Paper ID	IJIFR/V4/ E4/ 018	Page No.	5801-5806	Subject Area	Education
----------	-------------------	----------	-----------	--------------	-----------

Keywords	Transgender, Rights, Legal Steps, Education
----------	---

Dr. Nimmi Maria Oommen

**Assistant Professor
Department of Education
Titus II Teachers College
Tiruvalla, Kerala**

Abstract

Transgender people are people who have a gender identity, or gender expression, that differs from their assigned sex. Transgender people are sometimes called transsexual if they desire medical assistance to transition from one sex to another. Transgender is also an umbrella term: in addition to including people whose gender identity is the opposite of their assigned sex (trans men and trans women), it may include people who are not exclusively masculine or feminine. Transgender also comprise people who belong to a third gender, or conceptualize transgender people as a third gender. Being transgender is independent of sexual orientation: transgender people may identify as heterosexual, homosexual, bisexual, asexual, etc., or may consider conventional sexual orientation labels inadequate or inapplicable. The term transgender can also be distinguished from intersex, a term that describes people born with physical sex characteristics that do not fit typical binary notions of male or female bodies. The degree to which individuals feel genuine, authentic, and comfortable within their external appearance and accept their genuine identity has been called transgender congruence. Most transgender people face discrimination at and in access to work, public accommodations, and healthcare. They are not legally protected from discrimination in many places. This article explains transgender and the various dimensions associated with it.

I. INTRODUCTION

Transgender means someone whose gender differs from the one they were given when they were born. Transgender people may identify as male or female, or they may feel that neither label fits them. They have a way of expressing themselves, describing their gender, or gender identity. In order to express their chosen gender, transgender people may



transition, or change, from the gender they were given at birth. They may change their names, pronouns or style of dress. Some transgender people also choose a medical transition, with the help of medical specialists, who will prescribe hormones and/or surgery. A Transsexual person lives in a different gender to the one they were given when they were born. For example, someone who was called a 'boy' when they were born may feel very strongly that they are really a girl. They would be called a trans-woman. If someone was labeled a 'girl' at birth, and they later realize that they are male, they would be called a trans-man. Gender Identity is a person's internal feelings, and the labels they use, such as male, female, or transgender.

Gender – key attributes

- For some, being male or female is something they don't think about, it's automatic.
 - Some people feel pressure to determine up to what's expected of them as male or female
 - Lesbian, gay, and bisexual people often feel that the only way to be a real man or a real woman is to be heterosexual/straight.
 - Some people feel that male or female are labels that don't work for them.
- Stereotypes of how boys and girls are thought to be:*
- Many people act like boys and girls are opposite to each other – completely separate and different.
 - Some people say that boys are supposed to like sports.
 - Girls can be expected to like pink and have long hair
 - Girls and boys can be encouraged to go into certain types of jobs and not others.

Transgender people are also dealing with these gender problems. Some people feel like they don't fit at all into the male or the female, they might call themselves transgender. Transgender people are individuals whose gender identities do not pertain to their biological sex, and thus they differ from the stereotype of how men and women normally are. Transgender does not include sexual orientation or physical sex characteristics, but is in fact a less clinical term which pertains to gender identity and gender expression. Thus transgender people include those people whose identity and behaviour do not adhere to the stereotypical gender norms. They may be gay, transsexual, or gender queer.

II. TRANSGENDERS IN INDIA

In India, transgender people include hijras/ kinnars, shiv-shaktis, jogappas, Sakhi, jogtas, Aradhis etc. In fact, there are many who do not belong to any of the groups but are transgender persons individually. Transgender fall under the LGBT group (lesbian, gay, bisexual and transgender). They constitute the marginalized section of the society in India, and thus face legal, social as well as economic tides.

The problems faced by the transgender people in India include:

- These people are shunned by family and society alike.
- They have restricted access to education, health services and public spaces.

- Till recently, they were excluded from effectively participating in social and cultural life.
- Politics and decision-making processes have been out of their reach.
- Transgender people have difficulty in exercising their basic civil rights.
- Reports of harassment, violence, denial of services, and unfair treatment against transgender persons have come to light.

Sexual activity between two persons of the same sex is criminalized, and is punishable. In a landmark judgement in 2014, the Supreme Court observed that “The transgender community, generally known as “Hijras” in this country, are a section of Indian citizens who are treated by the society as “unnatural and generally as objects of ridicule and even fear on account of superstition”. In its judgement, the Supreme Court passed the ruling that “In view of the constitutional guarantee, the transgender community is entitled to basic rights i.e. Right to Personal Liberty, dignity, Freedom of expression, Right to Education and Empowerment, Right against violence, Discrimination and exploitation and Right to work. Moreover, every person must have the right to decide his/her gender expression and identity, including transsexuals, transgenders, hijras and should have right to freely express their gender identity and be considered as a third sex.” Thus, today the transgender people in India are considered to be the Third Gender.

Within the Third Gender population, there are many stories of determination; hard work and dedication where a transgender did not allow societal stress decide their fate. It is wrong to judge and discriminate people who may be different from the stereotype, which again is man-made. India now realised that every individual in this country has equal rights and privileges, and follow the policy of “live and let live.”

Family acceptance is the most important factor associated with their survival. Transgender are begging on the streets or doing sex work for livelihood because their families abandoned them. Their pitiable lives are the rejection and dishonor from their families. So parents should put a stop to from rejecting their gender nonconforming children and start accepting them. The greater part of the transgender people in our country are sex workers and beggars, and their lives need a positive change, they need to live in dignity. The human power of transgender people is being worn out; it should profit the country. As long as the community has no opportunity to track education, they will remain in darkness. The government's efforts, media like television, newspapers and magazines were also a very important reason for the constructive change which is happening. They told the truth about the community from a humanistic point of view, which made the society understand and open their hearts towards accommodating them.

III. LEGAL STEPLADDER - INDIA'S ACCEPTANCE OF TRANSGENDERS

From redrafting the Rights of Transgender Persons Bill, 2014 to including transgenders as beneficiaries in social security schemes, India is making great strides in ending discrimination of transgender persons in the country. Over the last few years, there have been important developments for eliminating the historic discrimination and exclusion of

transgender persons; and for ensuring that they are accepted in society and given equal opportunities and access to resources. In April 2014, the Supreme Court of India gave a major boost to transgender rights in India in by its decision recognized the right of transgender persons to adopt their self-identified gender as male, female or 'third gender.' Two recent developments that could demonstrate to be major steps forward for the rights of transgender persons are:

- (i) Redrafting of the Rights of Transgender Persons Bill, 2014 and
- (ii) Extension of social security schemes by the Odisha Government to transgender persons.

These steps are important for ensuring that transgender persons are accepted within the fold of society and have access to the same resources and opportunities as other members of the society.

Redrafting of the Rights of Transgender Persons Bill

The Rights of Transgender Persons Bill, 2014 was passed by the Rajya Sabha in April 2015. The Bill manifests many aspects of the Supreme Court's judgment such as social welfare measures for transgender persons and measures to raise awareness on issues of transgender rights. A committee of the Ministry of Social Justice and Empowerment cleared the Bill after including a chapter that defines various atrocities and violence against transgender people as offences. Some of the offences included in the newly-added chapter are as under:

- i.) Forcibly removing the clothes of a transgender person, and parading them naked
- ii.) Making transgender persons commit forced or bonded labour
- iii.) Enticing a transgender person to beg
- iv.) Forcibly dispossessing a transgender person from his/her house, village or other place of residence
- v.) Intentionally insulting or intimidating with the intent to humiliate a transgender person in a public place
- vi.) Denying them access to a place of public resort; and
- vii.) Committing any act derogatory to human dignity.

Many of these acts constitute offences under the existing criminal law as well. True impact of the redrafted Bill can be assessed after the text is made available to public. The redrafted Bill is important to ensure that the many gruesome acts responsible for the social exclusion of transgender persons are stopped. Ill-treatment of transgender persons is a social evil that needs to be tackled effectively by law as well as by creating awareness. The Bill also provides for constitution of a National Council for Transgender Persons to advise Central and State governments on issues relating to the rights of transgender persons. However, there is a lack of sufficient political will in the Government and Lok Sabha to pass the Bill. There is also a concern that the final law may be a diluted version of the draft Bill. Passing of the Bill into law is important to implement the transgender rights that have been recognized by the Supreme Court.

The legal developments relating to the rights of transgender persons have led to the emergence of many stories that showcase greater inclusion and acceptance of transgender

persons in the society. Transgender persons need no longer hide their identity. The legal side will give transgender persons the space to build the life they desire for themselves. They will be able to pursue their education, get jobs and participate as equal citizens. This is an important step for building an inclusive, accessible and diverse India. The Union government has made no provision for reservation in jobs and education in the transgender Bill that was introduced in the Lok Sabha. According to an earlier draft of the Cabinet note prepared by the Ministry of Social Justice and Empowerment, all transgender persons, barring those who are not from Scheduled Castes and Schedules Tribes, were to be considered in the reservation quota for Other Backward Castes (OBC).

The Transgender Persons (Protection of Rights) Bill, 2016, introduced by Minister for Social Justice and Empowerment has no mention of the reservation. Ministry said that it was dropped because of protests by OBC groups who feared this would shrink their share of the pie. The earlier draft Cabinet note had a section on reservation in employment. It read, "Those transgender persons who by birth do not belong to Scheduled Caste or Scheduled Tribe may be declared as Backward Class and be entitled to reservation under the existing ceiling of OBC category." As for transgender persons belonging to SC and ST communities, they were to take benefit under the existing reservation quota available for these categories, it had said. "Ever since the draft was circulated by us, the ministry received representations from OBC groups who were staunchly opposed to the proposed move," said a ministry source. The government had to take up the issue of reservation under OBC quota for transgenders following an August 2014 recommendation by the National Commission for Backward Classes (NCBC) in favour of the inclusion of transgenders in the central list of OBCs. "The Supreme Court judgment in the case filed by the National Legal Services Authority Vs Union of India said that the Centre should treat them as socially and educationally backward classes and provide them with the reservations available to them. We elaborated on the SC order in our report and said that all transgenders from forward castes should be given reservation under the existing 27 per cent quota for OBC," said NCBC member S K Kharventhan. The government Bill on transgenders' rights came in the wake of a similar Bill introduced in Rajya Sabha by DMK MP Tiruchi. The private member Bill, the first such to be passed in over four decades, spoke of reservation in not only jobs but also in education - an assured two per cent reservation. "Instead of two per cent, it could even be 0.5 per cent but it has to be only horizontal reservation. This means that within the existing reservation quota for OBCs, SCs and STs, there must be an assured per cent of reservation for transgenders as they cannot easily get jobs and education if they are made to compete with others in each category.

IV. CONCLUSION

Gender is the construct of mind to a certain level. Born as transgender is not the foremost issue, but to live as transgender is the most difficult side. Let us recognize, approve and accept that they are also born in this world beautifully. So let they lead a beautiful life wrapped with love and peace.

V. REFERENCES

- [1] Anand C. L. & et al. (1983). *The Teacher and Education in the Emerging Indian Society*, New Delhi: N.C.E.R.T.
- [2] Dash B.N. (2002). *Teacher and education in the emerging Indian society* (2 volumes). Hyderabad: Neelkamal Publications
- [3] <https://en.wikipedia.org/wiki/Transgender>
- [4] <http://www.belongto.org/group.aspx?contentid=2918>
- [5] <http://www.mapsofindia.com/my-india/government/the-life-of-transgenders>
- [6] <http://timesofindia.indiatimes.com/city/kochi/Opportunity-for-education-is-the-way-forward-for-the-transgender-community-Kalki-Subramaniam/articleshow/52523445.cms>
- [7] <http://www.thebetterindia.com/59151/transgender-rights-in-india/>
- [8] <http://indianexpress.com/article/india/india-news-india/transgender-bill-has-no-provision-for-quota-in-jobs-education-2954328/>

To Cite This Article

Oommen, M. A. (2016): “A Sketch Out On Transgender -Educational Insights”
International Journal of Informative & Futuristic Research (ISSN: 2347-1697), Vol. 4 No. (4), December 2016, pp. 5801-5806, Paper ID: IJIFR/V4/E4/018.

CHALLENGES OF TESTING IN AGILE METHODOLOGY: A REVIEW

Paper ID	IJIFR/V4/ E4/ 019	Page No.	5807-5813	Subject Area	Computer Sci.
Keywords	Traditional Methodology, Agile Methodology, Test-Driven Development				

1 st	Neetika Jain	Assistant Professor Department of Computer Science & Applications D.A.V. College for Girls, Yamuna Nagar, Haryana.
2 nd	Dr. Rachna Soni	Associate Prof essor & HOD Department of Computer Science & Applications D.A.V. College for Girls, Yamuna Nagar, Haryana.

Abstract

There are various methodologies available for developing and testing software. The method we choose depends on various factors such as the nature of project, the project schedule, and resource availability. Although all software development projects involve periodic testing, some methodologies focus on getting the input from testing early in the cycle rather than waiting for input when a working model of the system is ready. Those methodologies that require early test inclusion have couple of great conditions, furthermore incorporate tradeoffs terms of project management, schedule, client interaction, budget, and communication among team members. Agile Testing is an arrangement of timesaving techniques specifically designed to make the work of agile testing teams easier and more productive. It is an engaging procedure that produces great results and has a simple mission: Get the most ideal testing comes about with minimal measure of work an exact, targeted solution. Common challenges agile teams face and recommended solutions to handle them rapidly and effectively .These challenge and solution-based techniques do not require significant changes in your current work process. We can adopt them in increments, which empowers us to focus on one particular test and meet it head-on with a precise, targeted solution. Common challenges agile teams face and recommended solutions to handle them rapidly and effectively .This paper discusses about how testing fits and challenges into conventional/Agile approach and then discusses the test-driven development practice in Agile Methodology in detail.

I. INTRODUCTION

A Software Development Life Cycle (SDLC) adheres to important stages that are essential for developers, such as planning, analysis, design, and implementation, there are various programming improvement life cycle (SDLC) models have been made: waterfall, spiral, V-Model, rapid prototyping, incremental, Agile model. Different software development programming advancement models will focus the test effort at different points in the development procedure.. Newer development models, for example Agile, utilizes test driven development and place an increased portion of the testing in the hands of the developer, before it reaches a formal group of analyzers. In a more traditional model, the greater part of the test execution occurs after the requirements have been characterized and the coding procedure has been completed. By using test-driven advancement, we can ensure that each component of an application piece is thoroughly tried ahead of schedule in the Software project life cycle. Early testing fundamentally would solve majority of the issues that will be encountered by the development team and it will empower them to monitor every one of the defects.

1.1 KEY DIFFERENCES BETWEEN TRADITIONAL AND AGILE METHODOLOGY

- Development is incremental instead of sequential. Software system is developed in incremental, rapid cycles. This results in small, incremental releases, with every release building on previous functionality. Each release is completely tested, which ensures that all issues are addressed within the next iteration.
- People and interactions are emphasized, instead of processes and tools. Customers, developers, and testers constantly interact with one another. This interaction ensures that the tester is conscious of the requirements for the features being developed throughout a selected iteration and can easily identify any discrepancy between the system and the requirements.
- Working package is the priority rather than elaborate documentation. Agile methodologies rely on face to-face communication and collaboration, with people operating in pairs. Because of the intensive communication with customers and among team members, the project does not need a detailed requirements document.
- Customer collaboration is employed, rather than contract negotiation. All agile projects include clients as a part of the team. When developers have questions on a demand, they immediately get clarification from customers.
- Responding to change is finished, rather than intensive planning. However, it suggests changing the plan to accommodate any changes in assumptions for the plan, instead of attempting to follow the first set up.
- Agile testing was totally different in many ways from traditional software testing. The biggest difference is that on an agile project, the complete development team takes responsibility for quality. This implies the full team is responsible for all software testing tasks, including acceptance test automation. When software testers

and programmers work together, the approaches to check automation will be inventive.

1.2 CHALLENGES IN TRADITIONAL METHODOLOGY

- Significant delays between once software package is written and development receives feedback
- Defects found late within this process can have major implications when changed
- Changing business needs have an effect on check cases that have already been developed.
- Communications produce risk that different groups may have different expectations of the ultimate product
- Quality suffers and lots of QA activities get ignored once testing is the last activity before a fixed release date.

II. TESTING METHODOLOGIES

At the early years of software code development, most of the users' requirements were fairly stable, and development followed the plans without major changes. However, as software development concerned additional essential and dynamic industrial projects, new difficulties emerged in keeping with the expansion of companies. These difficulties include:

2.1 Evolving requirements:

Client requirements are dynamical due to evolving business needs or legislative problems. Most of the customers don't have a transparent vision regarding the specifications of their requirements at the early stages. Some customers understand what their true requirements are only when they use an application that doesn't really meet their needs. Another source of change comes from experiences gained throughout the development.

2.2 Customer involvement:

Lack of client involvement results in higher possibilities of project failure. Many companies usually don't assign any effort for client involvement.

2.3 Deadlines and budgets:

Usually, customers don't accept failure. On the opposite hand, companies usually provide low budgets, tight deadlines, whereas at constant time, requiring high demands, and every one of this can be owing to competition within the markets.

2.4 Miscommunications:

One cause for the misunderstanding of requirements is that the miscommunication between developers and customers. As an example, every party uses its own jargon, and this results in misunderstanding of customer's needs.

With the existence of such issues, the OO software system development methodologies cannot satisfy the objectives of software development companies. New development methodologies have to be applied so as to beat these issues. A number of IT professionals started to began to work individually on new approaches to develop software. The results of their researches were a set of new development methodologies that have several common features. When they met in conference in, they created the so called: Agile Manifesto.

These approaches were developed based on the same rule that the most effective way to verify a system is to deliver working versions to the clients, then update it according to their notes. Agile authors designed their methodologies on four principles: First, the main objective is to develop software that satisfies the clients, through continuous delivering of working software code, and obtaining feedback from customers concerning it. The second principle is accepting changes in requirements at any development stage, so that clients would feel more comfortable with the development process. The third principle is that the cooperation between the developers and the clients (business people) on a daily basis throughout the project development. The last principle is developing on a test-driven basis; that's to write test prior to writing code. A test suite is run on the application when any code change. Agility briefly suggests that to strip away the maximum amount of the heaviness, commonly associated with traditional software development methodologies, as potential, so as to promote quick response to dynamical environments, changes in clients requirements, accelerate project deadlines, and the like. Agile methodologies prefer software code development over documentation. Their philosophy is to deliver several working versions of the software package briefly iterations, then update the software according to customers feedback. Applying this philosophy will help to beat the issues mentioned earlier, by welcoming changes, satisfying user requirements, quicker development, and at the end, users will have just the system they need.

III. BENEFITS OF AGILE TESTING

- On-going feedback to developers permits testers to ask the right questions at the right time.
- Early identification of dependent, technical or testing challenges and road blocks.
- Embraces modification as a healthy and real part of software development.
- Team collaboration helps everybody work together toward a common goal.
- Quality comes initial as a result of final acceptance criteria are established before the work starting.

IV. KEY CHALLENGES FOR TESTER IN AGILE PROJECT

4.1 Scrum Master

A Scrum Master is a team leader and assistant who help the team members to follow agile practices so they will meet their commitments. The responsibilities of a scrum master are as follows: To enable close co-operation between all roles and functions, To take away any blocks, To shield the team from any disturbances, To work with the organization to trace the progress and processes of the corporate. To make sure that Agile Inspect & Adapt processes are leveraged properly which includes: Daily stand-ups, Planned conferences, Demo, Review, Retrospective Meetings, and To facilitate team meetings and decision-making method.

4.2 Product Owner

A Product Owner is the one who drives the product from business perspective. The responsibilities or a Product Owner are as follows: To outline the requirements and

prioritize their values, To confirm the release date and contents, To take an active role in iteration planning and release planning meetings, To make sure that team is functioning on the most valued requirement, To represent the voice of the client, To accept the user stories that meet the definition of done and defined acceptance criteria.

4.3 Cross-functional Team

Every agile team ought to be a self-sufficient team with 5 to 9 team members and an average expertise starting from of 6 to 10 years. Typically, an agile team includes of 3 to 4 developers, 1 tester, 1 technical lead, 1 product owner and 1 scrum master. Product Owner and Scrum master are considered to be a part of Team Interface, whereas alternative members are part of Technical Interface.

V. PROCESSES FOLLOWED IN TRADITIONAL TESTING

Firstly receive requirements document from the client then proceed to review then eventually can get requirements document that's considered base lined or signed-off. After this Analyses these requirements to create test conditions and test cases then Write test procedures and wait for a bit of software to miraculously appear in test environment. Then now start executing tests. Now begin re-executing a number of these tests as you now start iterating through new builds that are released to fix bugs or they may even include new functionality. Then reach the appropriate risk, enough testing point (or the fastened stable point) and the software is released

Table -1: Agile Development Manifesto

Individuals And Interactions	Processes And Tools
Working Software Product	Comprehensive Documentation
Customer Collaboration	Contract Negotiation
Responding To Change	Following A Plan

According to agile manifesto shown in table, agile software development approach permits requirements changes and it means that changes is created conjointly in check cases. That method needs higher communication between developers, testers and finish users so as to beat the issues and build a lot of versatile and optimized solutions. The individual people and their interactions are the most necessary part in the project, i.e. the collaboration between the team members is responsible for higher learning atmosphere where new members may learn things from the senior and most experienced team members. Since agile development needs multifunctional groups that follow the principles of iterative and incremental developing practices, the testing method ought to be efficient and it needs creating tests early and often. There should be clear definition what the results of testing ought to be at the end of each sprint. It means that tests have to be done before the implementation of the project functionalities in every sprint.

The key issue of successful testing is close collaboration between end users, developers and testers. Testers should be a part of the development team and every activities must be parallelized as much as possible. As an example, while testers are working on test cases,

developers are coding the user stories. Because the agile development paradigm says that every processes should be done fast, there's no such a lot time for testing, so the test data preparation should be done in the planning phase in the development process . Better approach is these take a look at information to be ready at the side of the stakeholders so as to satisfy the functional and performance requirements.

- **How an Agile Team Plans its Work?**

An Agile team works in iterations to deliver user stories where every iteration is of 10 to 15 days. Each user story is planned supported its backlog prioritization and size. The team uses its capability – how many hours are available with team to work on tasks – to make a decision how much scope they have to plan.

VI. CONCLUSION

In this paper, we described the various testing approaches to software system development through traditional and agile methodologies. Furthermore, we initially criticized on both traditional and agile methodologies followed by the comparison. Agile methodologies came into existence after the requirement for a lightweight to do software code development so as to accommodate changing requirements environment. Agile methodologies give some practices that facilitate communication between the developer and therefore the client, and undergo develop-deliver-feedback cycles, to possess additional specific view of the requirements, and be prepared for any amendment at any time. The most aim of agile methodologies is to deliver what's needed when it is needed. Further, we discussed on benefits, analysis on take a look at driven development & tester challenges in both traditional and agile methodology. The requirement for business to reply rapidly to the environment in an innovative, cost effective and economical means is compelling the utilization of agile methods to developing software system. The future of agile methodologies appears terribly dominant. In general, there are some aspects of software development project that will benefit from an agile testing approach and others can benefit from a more predictive traditional testing approach.

VII. REFERENCES

- [1] [Peterson, K. (2010a). "Doctoral research in Sweden Implementing Lean and Agile Software Development in Industry".
- [2] Koskela, Lasse. (2007). "Test Driven: Practical TDD and Acceptance TDD for Java Developers". Manning Publications Co. Greenwich, CT, USA.
- [3] Nawaz, A. and Masood, M. K. 2008. Software Testing Process in agile development. Master thesis. Blekinge Institute of Technology, Sweden.
- [4] Weisert, Conrad (2003). "Waterfall Methodology: there's no such thing!". Retrieved on 18 April 2014 from <http://idinews.com/waterfall.html>.
- [5] [5] "Overview of the Activity Model of the V-Model"(2006). Retrieved on 20 April 2014 from <http://v-modell.iabg.de/v-modell-xhtml-english/>.
- [6] Palmer, Steve & Felsing, Mac (2001). "A Practical Guide to Feature-Driven Development(1st ed.)". Pearson Education.

- [7] Beck, Kent, et al. (2001). "Manifesto for Agile Software Development". Agile Alliance. Retrieved on 7 April 2014, <http://agilemanifesto.org>.
- [8] Beck, Kent (2002). "Test-Driven Development by Example". Addison-Wesley Longman Publishing Co. Inc., Boston, MA, USA.
- [9] Pettichord, Bret. (2002). "Agile Testing: What is it? Can it work?" Retrieved on 9 April 2014 from <http://www.sasqag.org/pastmeetings/AgileTesting20021121.pdf>.
- [10] Crispin, Lisa (2003). "XP Testing Without XP: Taking Advantage of Agile Testing Practices". Retrieved on 17 April 2014 from <http://www.methodsandtools.com/archive.php?id=2>.
- [11] Highsmith, Jim and Cockburn, Alistair (2001). "Agile Software Development: The Business of Innovation". Addison-Wesley, 2001.
- [12] J. Erickson, K. Lyytinen and K. Siau, Agile Modeling, Agile Software Development, and Extreme Programming: The State of Research. In *Journal of Database Management*, 16(4), 2005, 88-100.
- [13] Larman, Craig (2003). "Agile and Iterative Development: A Manager's Guide". Pearson Education. Agile Alliance. Manifesto for Agile Software Development. [Online] Retrieved 16th March 2009. Available at: <http://www.agilemanifesto.org>.
- [14] D. Turk, R. France and B. Rumpe, Limitations of agile software processes. In *Proceedings of the Third International Conference on Extreme Programming and Flexible Processes in Software Engineering*, 2002.

To Cite This Article

Jain, N. , Soni, R. (2016): "Challenges Of Testing In Agile Methodology-A Review " *International Journal of Informative & Futuristic Research (ISSN: 2347-1697)*, Vol. 4 No. (4), December 2016, pp. 5807-5813, Paper ID: IJIFR/V4/E4/019.

ANTHROPOMETRIC INDICES AND BODY COMPOSITION OF SALTPAN WORKERS IN THOOTHUKUDI DISTRICT, TAMIL NADU

Paper ID

IJIFR/V4/ E4/ 021

Page No.

5814-5821

Subject Area

Food Science and Nutrition

Keywords

Saltpan Workers, Anthropometry, Body Composition

1 st	Mathuravalli. S.M.D	Associate Prof essor Department of Food Science and Nutrition Holy Cross Home Science College, Thoothukudi, Tamil Nadu
2 nd	Dr. Sr. Mary S.A	Associate Professor, Department of Home Science, Fatima College, Madurai, Tamil Nadu
3 rd	Dr. B.Geetha	Associate Professor, Department of Zoology, V.O.C.College, Thoothukudi, Tamil Nadu

Abstract

The study was conducted to determine the anthropometric measurements and body composition of selected saltpan workers. A total of 121 men and 168 women saltpan workers from 20 saltpans of Thoothukudi district were studied. The height and body weight of respondents were measured using the weighing balance and anthropometer. The skin fold thickness measurements were taken using the Harpenden Calipers at four sites (biceps, triceps, subscapular and suprailiac). The percentage of body fat was calculated from the sum of four measurements of skinfold thickness. Based on body mass index (BMI), the prevalence of low weight (18.5-19.9 kg/m²) (>30 per cent) and CED II moderate (>50 per cent) of men and women respondents indicates their poor health. The body composition of the men workers in terms of body fat, BSA, waist and hip circumferences was positively associated with their activity level. The MUAC and skin fold had no effect. In women workers, the parameters such as BMI and BSA were statistically significant at 1 per cent level but lean body mass and WHR was statistically significant at 5 per cent level. The MUAC and skinfold values measure were not statistically significant.

I. INTRODUCTION

The economic growth of a country depends on the rate of industrialization. However, the industrialization may not be achieved in the absence of any one of the factors, namely land, labor, capital and organizations. Though all the four factors of production seem to be equally important, still the progress of the industry mainly depends on the productive efficiency of the labor force. Therefore, the workers should be considered as the most important factor for the growth of an industry. The salt industry is the mainstay of the area's economy of Thoothukudi district but its socioeconomic and ecological contribution has not been fully realized. It occupies a very important place in the history of the salt industry in India because of its geographic location and other favorable factors. There are three types of saltpans viz., small, medium and large pans in Thoothukudi district and about 50 per cent of the salt sectors are unorganized. The process of salt production is by solar evaporation and is also a seasonal activity. The salt production work carried out from the month of February to September. The salt industry is labour intensive and employs over 40,000 direct workers producing annually over 25 lakh tons compared to Gujarat's 90 lakh tons (Madhu, 2006).

Persistent poverty, indebtedness and deprivation are common to all the saltpan workers, the women, as in many other poor communities become greater victims of poverty in Thoothukudi district. The BOBP-IGO (2013) of Government of India accepts that "saltpan workers are poorest of the poor in India". They live in extreme poverty situation because they are voiceless, powerless and resource poor. Poverty is one of the most responsible factors for underfeeding and malnutrition. Marginalization of population based on income, gender or ethnicity forces people to make very few choices to select foods. These forced choices may affect the short term or long term health outcomes. The physical characteristics and body composition have been known to be fundamental to excellence in work performance of the workers. However, there has been no information on anthropometric and body composition data of saltpan workers. The purpose of this study was to collect baseline data on anthropometric measurements and body composition of men and women saltpan workers and to compare those with standards. The saltpan work is also characterized by its casual nature, the temporary relationship between employer and employee, uncertain working hours, lack basic amenities and inadequate welfare facilities. It is truly said that the taste of the food is due to the salt, it is poignant to note that the salt workers take so much pain to give taste to the food.

II. METHODOLOGY

A total of 121 men and 168 women saltpan workers from 20 saltpans of Thoothukudi district were randomly selected for the study. The height and body weight of respondents were measured using the weighing balance and anthropometer. The height and weight of respondents (barefooted and in light clothing) were measured to the nearest 0.5 cm and 0.1 kg, respectively, using the SECA weighing balance with height attachment. Skin fold thickness measurements were taken using Harpenden Calipers at 4 sites (biceps, triceps,

subscapular and suprailiac) as recommended by Durnin and Rahaman (1967). The fat content as percentage of body weight was calculated from the sum of four measurements of skinfold thickness (Durnin and Womersley, 1974). The body mass index (kg/m²) was also calculated for each respondent. Body weight classification for respondents was determined as described by Bray (1979). Results were presented as a mean ± SD range. The anthropometric and body composition data of the saltpan workers were compared with non-saltpan workers (Ismail and Zawiah, 1988). The statistical differences in anthropometric and body composition data of the saltpan workers and non-saltpan workers were assessed by t-test.

III. RESULTS AND DISCUSSION

3.1. Analysis of nutritional and health status of saltpan workers

The nutritional status of saltpan workers was assessed by anthropometric measurements (height, weight, Body Mass Index, skin fold thickness, Body Surface Area (BSA), Lean Body Mass (LBM), Body Fat percentage (BF%), Waist and Hip circumferences, Waist-Hip Ratio (WHR), biochemical estimation, clinical examination and dietary assessments were also considered as a measure of health status. The table 1 highlights the mean height of the respondents and the survey findings showed that the height of the workers ranged between 153 and 175 cm.

Table 1: Mean Height of the selected respondents

S.No.	Range of Height (in cm)	Men (n=121)		Women (n=168)	
		*ICMR =172 cm		*ICMR =161 cm	
		No.	%	No.	%
1.	<156	9	7.44	26	15.48
2.	156-160	13	10.74	89	52.98
3.	161-165	21	17.36	35	20.83
4.	166-170	36	29.75	18	10.71
5.	>170	42	34.71	0	0
Total		121	100	168	100

***ICMR- Indian Council of Medical Research (2010)**

It is evident from the data that 34.71 per cent of the men respondents were in the height range of above 170 cm, whereas 52.98 per cent of the women respondents (>50 per cent) had the height between 156 and 160 cm. The mean height of men and women workers was 174.6 cm and 159.5 cm respectively. It is revealed from the present study that more than 30 per cent and 50 per cent of the selected men and women workers had the height of more than 170 cm and between 156 and 160 cm as against the ICMR (2010). Hence, it is obvious that the height of the men workers was found to be higher (than 170 cm) but the selected women workers were found to be slightly shorter stature according to ICMR reference values. The mean weight of the respondents is given in table 2 and fig 1. The results envisaged that none of the men respondents had the weight less than 50 kg.

Table 2: Mean weight of the selected respondents among saltpan workers

S.No.	Range of weight (in kg)	Men (n=121) *ICMR =62 kg		Women (n=168) *ICMR =56kg	
		No.	%	No.	%
1.	<46.0	0	0	24	14.29
2.	46.0-50.0	0	0	103	61.31
3.	51.0-55.0	16	13.22	34	20.24
4.	56.0-60.0	61	50.42	7	4.16
5.	61.0-65.0	44	36.36	0	0
Total		121	100	168	100

*ICMR- Indian Council of Medical Research (2010)

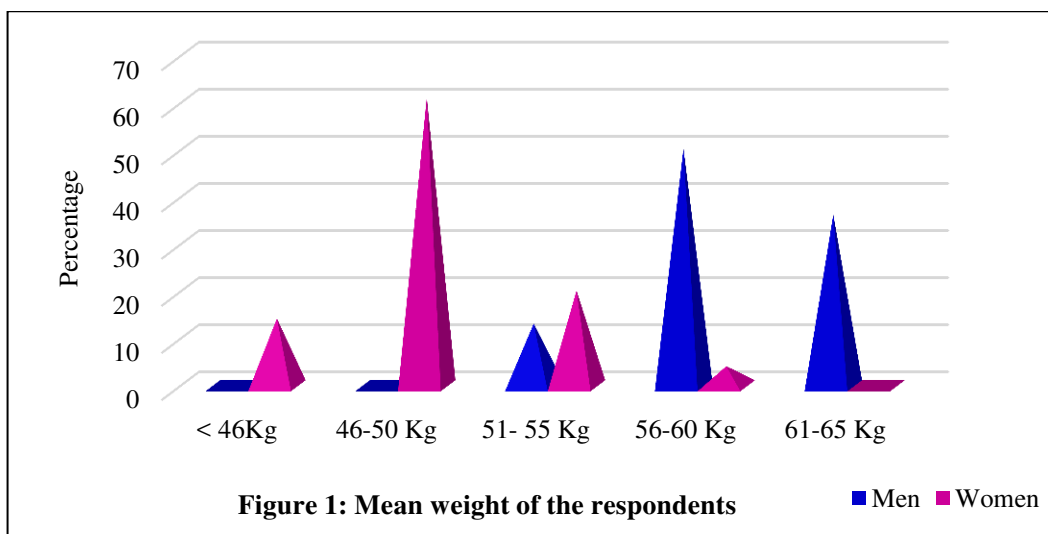

The results documented from the data indicated that above 50 per cent of men respondents and above 60 per cent of women respondents were found to be underweight between 56-60 kg and 46-50 kg which could be reasoned out due to a heavy schedule of work in both the groups. Reduction in body weight was noticed among both the worker groups because of negative energy balance and drudgery during their work, i.e., due to heavy strenuous task and being confined to their task without rest pause for long hours. It was also observed that none of the respondents fell either in overweight or obese categories. The results of overall anthropometric measurements expressed that most of the men and women workers were found to be undernourished which might lead to health problems in the long run. There was an increase in underweight among those in the lowest income groups (Sudo and Ohtsuka, 2001, Parkes et al., 2002 and Chinedu and Emiloju, 2014) which had a significant interaction with an increase in BMI among shift workers.

3.2. Body Mass Index

The table 3 and fig 2 presents the details regarding of the BMI of the selected saltpan workers calculated using height and weight data. The finding shows that the BMI of saltpan workers ranged between 15.6 - 24.8 kg/m². The mean BMI of men and women workers were 19.68 kg/m² and 16.36 kg/m² respectively.

Table 3: Distribution of the respondents as per BMI scores

Classification of Grade	Range of BMI (kg/m ²)	Men (n=121)		Women (n=168)	
		No.	%	No.	%
CED III Severe	<16.0	4	3.31	8	4.76
CED II Moderate	16.0-16.9	27	22.31	89	52.98
CED I Mild	17.0-18.4	34	28.10	28	16.66
Low weight	18.5-19.9	37	30.58	21	12.5
Normal	20.0-25.0	19	15.70	22	13.1
Total		121	100	168	100

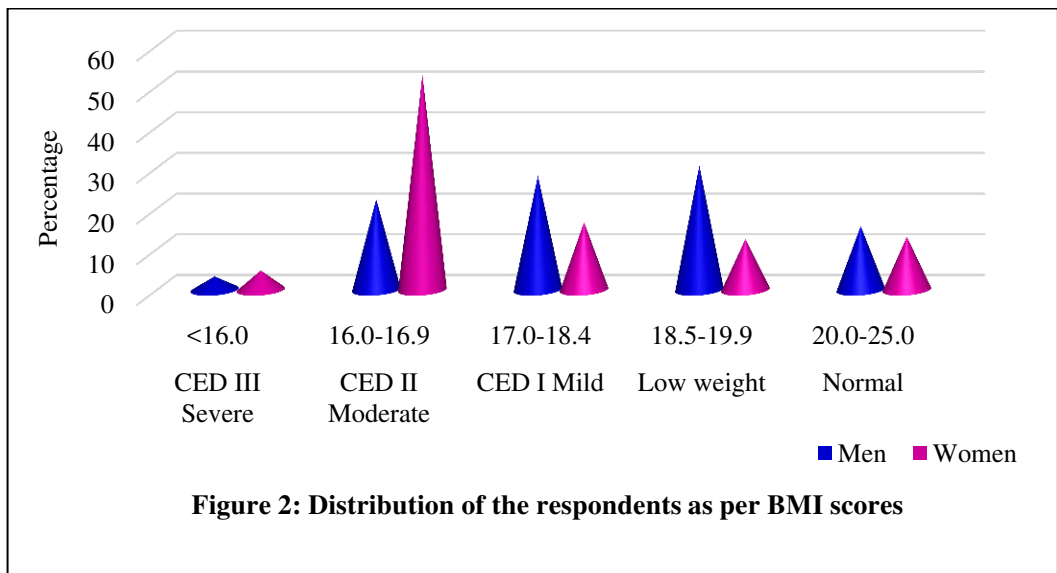

Figure 2: Distribution of the respondents as per BMI scores

The results of Sengupta and Sahoo (2011) showed that more than 8.2 per cent of the tea factory workers were reported to be underweight. The present study also indicates that the men respondents were also suffering from low weight and women respondents were suffering from CED II Moderate grade of Chronic Energy Malnutrition. In the present study, the prevalence of low weight (18.5-19.9 kg/m²) i.e., >30 per cent and CED II moderate (>50 per cent) in men and women respondents indicates the poor health of the selected respondents in terms of BMI which is in concordance with the similar studies from India (Bose and Chakraborty, 2005).

As people work in irregular hours, they are unable to maintain regular eating habits and the workers have a higher prevalence of being underweight. Dietary inadequacy, change of eating habits and other lifestyle changes among saltpan workers may lead to a decrease in BMI, which in turn leads to poor nutritional status.

3.3. Physical Characteristics

The details of physical parameters such as mean body fat percentage, body surface area, lean body mass, Mid-Upper Arm Circumference (MUAC), skin fold thickness, waist

circumference, hip circumference and WHR are presented in table 4. Of the men and women groups, the BSA of women workers is found to be lesser than men workers and statistically significant at 5 per cent level (2.06). All the workers were ectomorphic in status, which is attributable to the environmental conditions. The Lean Body Mass (LBM) of men (46.29±7.5 kg) and women (36.68±5.0 kg) was also statistically significant at 1 per cent level (3.32).

Table 4: Measurement of physical characteristics of the selected respondents

S.No.	Variables	Men (n=121)	Women(n=168)	't' value
1.	Body Fat (per cent)	16.6±2.2	17.2±2.68	2.78*
2.	Body Surface Area(m ²)	1.72±0.93	1.56±0.85	2.06*
3.	Lean Body Mass(kg)	46.29±7.5	36.68±5.0	3.32**
4.	MUAC (cm)	23.8±7.8	22.06±4.75	1.26 ^{NS}
5.	Skinfold Thickness (mm)	19.9±3.6	19.3±9.5	1.05 ^{NS}
6.	Waist Circumference (cm)	28.66±12.7	26.0±10.2	2.28*
7.	Hip Circumference (cm)	34.63±11.4	36.3±9.7	2.54*
8.	WHR	0.81±0.12	0.82±0.22	3.94**

*Significant at 5per cent level; **Significant at 1per cent level; NS-Non Significant

The MUAC was 23.8± 7.8 cm and 22.06 ±4.75 cm noticed among men and women workers and the result of MUAC was not statistically significant. In a study of Sengupta and Sahoo (2012), the MUAC of men tea factory workers was 24.5±2.40 cm whereas in the present study the selected saltpan workers found to have less MUAC than the men tea factory workers (22.75±4.2 mm). The sum of skinfolds of men workers was 19.9 ±3. 6 mm and in women workers was 19.3 ±9. 5 mm which is statistically insignificant?

The physical parameters such as mean body fat (2.78), BSA (2.06), waist (2.28) and hip circumferences (2.54) were statistically significant at 5 per cent level, whereas LBM (3.32) and WHR (3.94) were statistically significant at 1 per cent level which is caused by their poor nutritional status and economic condition. The women workers had high body fat percentage, hip circumference and WHR than the men workers. The present finding suggests that these respondents used all their physiological competencies to subsist at a daily level. Similar results were also noticed in the findings of Pal *et al.*, (2011). There was a significant positive relationship between BMI and physical activity (Benefice and Ndiaye 2005). The body fat (percentage) and lean body mass were statistically significant (2.78 and 3.32) at 5 per cent level. The Lean Body Mass was found to be higher among men (46.2±7.5 kg) than women workers (36.689±5.0 kg). The men workers have significantly greater values than women workers for all the measurements (except body fat and MUAC). The mean body fat (%) was noticed higher in women than men workers. The 't' value of body fat (%) was statistically significant at the 1% level (2.78*).

From the data, it is noticed that the body composition of the men workers in terms of body fat, BSA, waist and hip circumferences was positively associated with their activity level. The MUAC and skin fold had no effect. In women workers, the parameters such as BMI and BSA were statistically significant at 1 per cent level but lean body mass and WHR was statistically significant at 5 per cent level. The MUAC and skinfold values measure

were not statistically significant. The men respondents found to have high MUAC than women respondents. All the respondents displayed reduced body dimensions. The WHR is found to be significant between men and women respondents, which are another indicator of less fat percentage in women salt workers than men workers caused by their poor nutritional status and economic condition. The values of women respondents also indicated a delicate body builds. It is stated that there is no way for those women workers to avoid daily domestic tasks and those tasks need to be undertaken manually because of the absence of automation to alleviate their burden, even for strenuous tasks such as fetching/ carrying water. There are many circumstances in which nutritional status may affect productivity and well-being of workers.

IV. CONCLUSIONS

There was not much of a difference in the body weight, height and percentage of body fat between men and women saltpan workers, consistent with the physical need for the particular kind of work. But the body composition of the men workers in terms of body fat, BSA, waist and hip circumferences was positively associated with their activity level. The men and women saltpan workers had significantly lower body fat when compared to the standards. The mean body mass index and percentage of body fat were slightly lower in saltpan workers. This investigation indicates the need for further research on the effect of diets and training regime on body composition since it is associated with saltpan workers' performance. In addition, it would be interesting to compare the nutritional status and physical activity during work and at leisure time to get the baseline data to enable some adjustments to be made on current dietary intakes and activity levels of the saltpan workers.

V. REFERENCES

- [1] Benefice, E and G Ndiaye, (2005) Relationships between anthropometry, cardiorespiratory fitness indices and physical activity levels in different age and sex groups in rural Senegal (West Africa), *Annals of human biology*, Taylor & Francis, 32 (3), pp.366-82.
- [2] BOBP-IGO, 2013, The Saga of India's Salt workers, Bay of Bengal News, Available from http://bobpigo.org/html_site/bbn/march 06/Page%2037-40.pdf (accessed 1 November (2013).
- [3] Bose, K. and Chakraborty. F. (2005), "Anthropometric characteristics and nutritional Status based on body mass index of adult Bathudis: a tribal population of Keonjhar District, Orissa, India." *Asia Pacific Journal of Clinical Nutrition*, 14: 80-82.
- [4] Bray GA (1979), Obesity in American, Proceedings of the 2nd Fogarty International Center Conference on Obesity, Washington DC, NIH Publication, No 79.
- [5] Chinedu SN., and OC Emiloju, (2014), Underweight, overweight and obesity amongst young adults in Ota, Nigeria, *Journal of Public Health and Epidemiology*, Vol.6 (7) pp. 235-238.
- [6] Durnin JVGA and Rahaman MM (1967), The assessment of the amount of fat in the human from measurements of skinfold thickness, *Br J Nutr* 21: 681-68.
- [7] Durnin JVGA and Womersley J (1974), Body fat assessed from total body density and its estimation from skinfold thickness measurements of 481 men and women aged from 16-72 years, *Br J Nutr* 32: 77-97.

- [8] ICMR,(2010), Nutrient requirements and Recommended Dietary Allowances for National Institute of Nutrition Indian Council of Medical Research Jamai- Osmania Po, Tarnaka Hyderabad 500 007 p.18, 254-255.
- [9] Ismail MN and Zawiah H (1988), Energy requirements of Malaysian students, Proc Nutr Soc Mal 3: 63-72.
- [10] Madhu, S. R. 2006. Socio- Economic Status of Workers in the Salt Industry’ -The saga of India’s salt workers, BOBP-IGO report. pp37-40.
- [11] Pal B, Chattopadhyay M, Maity M, Mukhopadhyay B, Gupta R. Income and Nutritional Status of the Fishing Community Residing in Coastal Bay of Bengal: A Case Study, Anthropologischer Anzeiger 2011;68(2):195–208.
- [12] Parkes KR. Shift work and age as interactive predictors of body mass index among offshore workers Scand J Work Environ Health 2002;28(1):64—71.
- [13] Sengupta P. and Sahoo S. 2012, Fitness evaluation of young male tea factory workers of West Bengal. An ergonomic assessment and fitness evaluation of young male tea factory workers in Dooars, West Bengal. Prog Health Sci, Vol 2 , No1.
- [14] Sengupta,P and S.Sahoo, 2011, Evaluation of Health Status of the Fishers: Prediction of Cardiovascular Fitness and Anaerobic Power, *World J Life Sci. and Medical Research* 11(2) :25.
- [15] Sudo, N. and Ohtsuka, R., 2001, Nutrient intake among female shift workers in a computer factory in Japan, *International Journal of Food Science and Nutrition*,52: 367-378.

To Cite This Article

Mathuravalli, S.M.D, Sr. Mary, S.A, Geetha, B. (2016): “Anthropometric Indices And Body Composition Of Saltpan Workers In Thoothukudi District, Tamil Nadu” *International Journal of Informative & Futuristic Research (ISSN: 2347-1697)*, Vol. 4 No. (4), December 2016, pp. 5814-5821, Paper ID: IJIFR/V4/E4/021.

USE AND USER PERCEPTION OF ONLINE INFORMATION RESOURCES AMONG THE RESEARCH SCHOLARS OF PERIYAR UNIVERSITY, SALEM (TN), INDIA

Paper ID	IJIFR/V4/ E4/ 022	Page No.	5822-5832	Subject Area	Library & Information Sci.
Keywords	User Study, Online Resources, Periyar University, Salem, Tamilnadu				

1 st	Shankar. R	Research Scholar Department of Library and Information Science, Periyar University, Salem, Tamilnadu, India
2 nd	Dr. M. Jayaprakash	Assistant Professor , Department of Library and Information Science, Periyar University, Salem, Tamilnadu, India

Abstract

The contemporary era is the electronic era or era of knowledge and information revolution. A number of electronic resources are available in library or information resource centres or knowledge centre. The present study has made an attempt to identify the information needs and usage pattern on electronic resources for research scholars' of Periyar University in Salem District. The total numbers of 150 questionnaires were distributed to research scholars. Out of 150, the filled questionnaires were received at the rate of 79.33%. The simple random sampling technique was adapted to collect samples from the population. The findings of the results reveal based on the analysis and found that 36.975% of respondents were Male and the rest of them were Female. The majority of 51.2605% of respondents was in the age group of 31-35 and noticed that the average number of 33.33 % was identified overall study period. The study has identified and discussed many more features during the period of study.

I. INTRODUCTION

This is an information era and the written communication such as text books, reference books, research articles, conference proceedings, letters, memos, newsletters, leaflets, hand books, manuals, research reports and so on which are available in the form of paper bound. Now these are coming through online due to drastic change on Information and



Communication Technology (ICT). With the advent of ICT, people collect information very quickly using Internet. Hence, it is right time to analyze the behavior pattern of research scholars who far the internet facilities are being used by them. In 17th September 1997, the Government of Tamil Nadu has established the Periyar University at Salem as per the provisions of the Periyar University Act, 1997. The University includes the districts of Salem, Namakkal, Dharmapuri and Krishnagiri. The University got the 12(B) and 2f status from the University Grants Commission and has been accredited by NAAC with A Grade in 2015. The University is named after the Great Social Reformer E.V.Ramasamy affectionately called "Thanthai Periyar". The University aims at developing knowledge in various fields to realize the maxim inscribed in the logo "Arival Vilayum Ulagu" (Wisdom Maketh World).

University Central library was established in 1997. It has 78,580 volumes of text and reference books on various disciplines as on 15th August 2016. The library is having good number of national and international journals and 13 leading news papers subscribe 196 national and international journals and 13 leading news papers. The library is following open access system and provides services to meet the requirements of PG students, M.Phil, Ph.D. Scholars and faculty members of the University. The library has various sections such as reference section; Periodical section; Digital library text book section book for competitive Examination, Theses & Dissertations section, Back volumes section, Reprographic Section, Question Banks etc and Library also extends its facilities to the students and faculties of affiliated colleges.

II. RELATED WORK

The review of literature tells the earlier studies which were conducted by the researchers and eminent scholars to avoid unintended repetition of well established findings. Nikam and Rashmi (2015) made an attempt to know about the use of E-Resources by the Academia of Speech and Hearing Discipline at the All India Institute of Speech and Hearing (AIISH), Mysore. The results was revealed that Large users (56) were in the range of 21-25 years of age and nearly, 24.16% of respondents were specialized in speech and hearing. E-journals (mean=1.40) and e-databases (mean=0.80) were extensively used. Web Crawler (mean=0.33) is the most frequently used Meta search engine. The positive impact is 'Access to current/up-to-date information' (mean =1.60). The negative impact is too much of information is available (mean=1.40). Kalbande,; Shinde, and Ingle (2013), have studied the issues like use of electronic information resources, its impact on the collection of print and electronic sources its awareness among the users, and the places where the users are accessing these resources. A survey was conducted in the academic year 2010-11 at the Mahatma Phule Agricultural University, Rahuri (M.S). The findings showed that users were using e-resources; the awareness about e-resources encourages users to use such resources to the maximum; and the users are using Department and home more for accessing the information. The impact of e-resources was visible from the decrease in number of printed documents in comparison to the increase in number of electronic

resources and the use of e-resources has increased manifold and also the printed material is being quickly replaced by the electronic resources.

Biradar, B.S. et al. (2008) reports the results of a study exploring University students' and teachers' use of search engines for retrieval of scholarly information. The findings of the results showed that 100% of the students and 97.91 % of faculties use search engines for retrieval of information on the internet. Goggle and Yahoo receive the highest overall ratings. Velmurugan (2013) conducted study on the use and user perception of electronic resources in Siva Institute of Frontier Technology which is located in Chennai. The results showed that the highest frequency of using the electronic resources in the library was "twice a week" by 53.65% of the respondents. The purpose of using electronic resources most by the respondents (34.14%) was "to prepare for projects". The purpose of using electronic resources lest by the respondents (6.51%) was "to write book reviews". The majority of the respondents (68.29%) were satisfied and 13.82 % of the respondents were not satisfied. Mishra, Yadav and Bisht (2005) conducted a study to know Internet utilization pattern of the undergraduate students of G B Pant University of Agriculture and Technology at Pantnagar. The findings of the study also showed that 61.5% of the males and 51.6% of the females used Internet for preparing assignments. A majority of the respondents i.e. 83.1% male and 61.3% female respondents indicated that they faced the problem of slow functioning of Internet connection.

Henley (2004) has studied about digital reference services for young library users: a companion of four services, Scotland and found that the improvements in the design of the question form and services geared towards certain sections of society, at least in the case of children, would improve the nature of the service provided and may provide instruction in information searching as well as encourage greater use of the web. Carlson, Bethany and Reidy, Sharson (2004) carried out the study about Effective access: teacher's use of digital resources (research in progress). The results showed that all of the subjects in this sample have sought out educational resources on the web and a majority of educators, 84 % spend less than 50 % of their time using web – based resources during instructions.

III. OBJECTIVES OF THE STUDY

The study was an attempt to observe the information needs and usage pattern of resources by the research scholars of Periyar University, Salem. The study was conducted to achieve the following objectives.

1. To identify the awareness regarding electronic resources among the users
2. To investigate the demographic profile of research scholars
3. To examine the purpose of using the library resources
4. To study the frequency level of library visit
5. To find out the usage of various library resources
6. To identify the problem faced while accessing library resources and
7. To know the level of satisfaction among the users community.

IV. NEED FOR THE STUDY

Due to the drastic growth and development of Information and Communication Technology, the traditional mode of learning system has converted in to a greater extent. In this electronic age, gathering information, storage and processing them becomes easy due to invention of networks. As Internet offers many services, it serves to the society on various kinds of discipline and its usage for research purposes have been on the high rise. Browsing becomes a part of human life in the present day environment. The present study aims at identifying the information needs and usage pattern of resources for research scholars' of Periyar University in Salem District.

V. METHODOLOGY

The data for this study were collected from primary sources through questionnaire. Initially, secondary sources of data were collected from books, journals, and websites for identifying the population and sample. The unit of analysis in this research study is research scholars of Periyar University Salem. Simple random sampling technique was adapted to collect samples from the population. The total numbers of 150 questionnaires were distributed to research scholars. Out of 150, the filled questionnaires were received at the rate of 79.33%. The study is specific to research Scholars of Periyar University only. Since, the study participants were drawn from university department of research scholars the study may not be generalized and the study includes the data from the category of PhD Scholars only. The data thus collected were analyzed using simple percentage calculation.

VI. ANALYSIS AND FINDINGS

The present study has been carried out at Periyar University campus in Salem during 2016. This study was undertaken to analyze the usage pattern and level of understanding of Internet among the user community of PhD research scholars.

1. Distribution of Respondents by Gender

Table 1 and Figure 1 shows that 44 (36.975%) respondents were Male and the rest of 75 (63.02%) were Female. It was found that most of the respondents were from Female and ranked top between them.

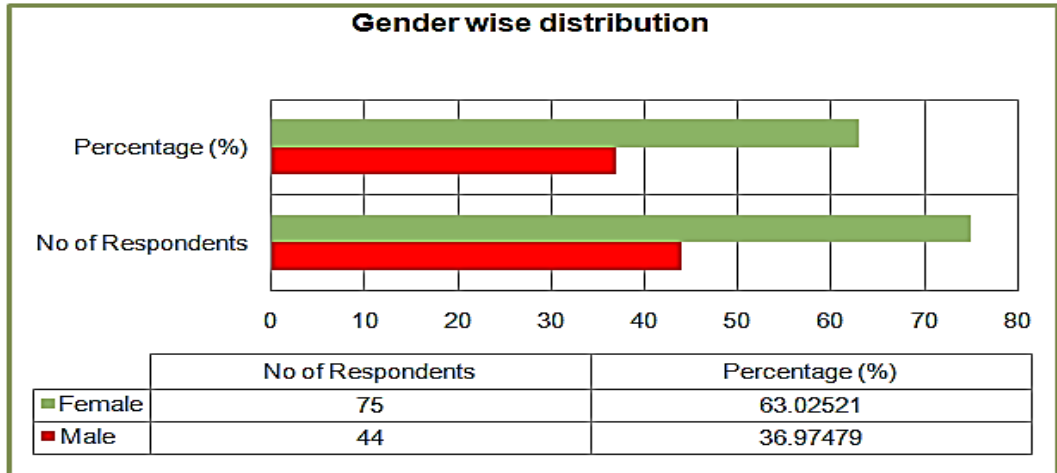

Figure1: Gender wise distribution
Table 1: Distribution of Respondents by Gender

Sl. No	Gender	No of Respondents	Percentage (%)
1	Male	44	36.97479
2	Female	75	63.02521
Total		119	100

2. Distribution of Respondents by Age

Table 2 (Fig. 2) represents the age wise distribution of respondents during the period of study. It is found that the majority of 61 (51.2605%) respondents were in the age group of 31-35, followed by 34 (28.57143%) respondents were 25-30 years, 24 (20.16807%) respondents were belong to above 24 years. The results show that the major part of the respondents was belonging to second category i.e. 31-35 age groups. It is found that he average number of 33.33 % were identified overall study period.

Table 2: Distribution of Respondents by Age

Sl. No	Age Group	No of Respondents	Percentage (%)
1	25 to 30	34	28.57143
2	31 to 35	61	51.2605
3	Above 35	24	20.16807
Total		119	100

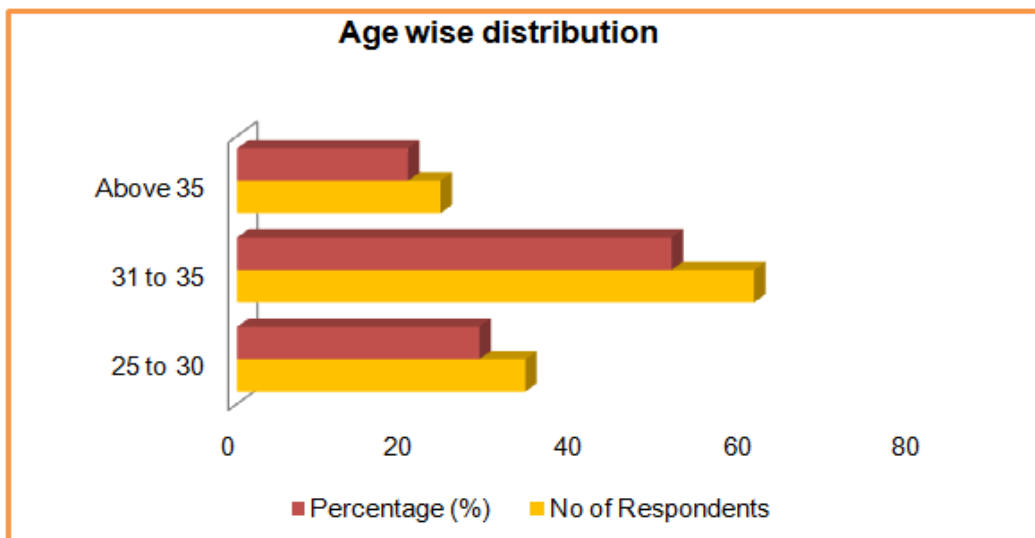

Figure 2: Age wise distribution

3. Distribution of the Respondents by Course

Respondents were asked to indicate their course to note down in their response sheet during the period of study. Based on the study, table 3 (Fig.3) identifies that out of 119 respondents, the maximum number of 39 (32%) respondents was from the School of Mathematics and ranked first and followed by School of Social Sciences with 28 (23.52%) respondents and placed second place and School of Languages (23), School of Professional Studies (12), School of Life Sciences (09) and School of Business Studies with 08 respondents filled their response sheet. the findings of the study shows that the majority of

respondents were participated from the school of mathematics which includes Computer Science, Library and Information Science and Mathematics.

Table-3: Distribution of the Respondents by Course

Sl. No	Course	No of Respondents	Percentage (%)
1	School of Mathematics	39	32.77311
2	School of Social Sciences	28	23.52941
3	School of Languages	23	19.32773
4	School of Professional Studies	12	10.08403
5	School of Life Sciences	09	7.563025
6	School of Business Studies	08	6.722689
Total		119	100.0

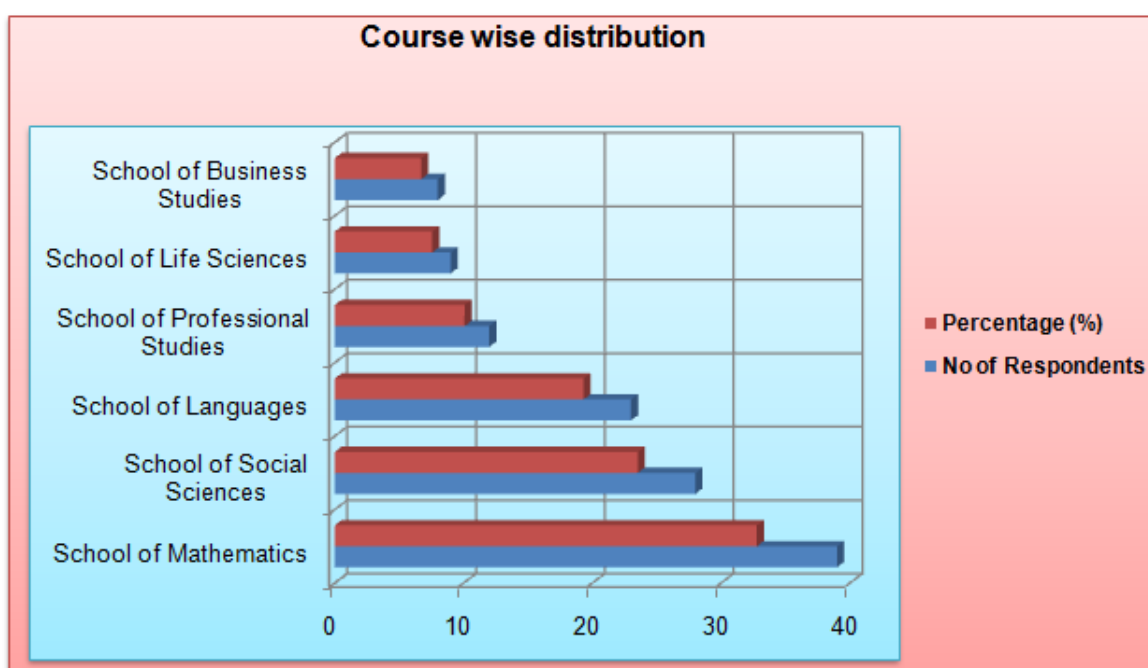

Figure 3: Course wise distribution

4. Marital status–wise distribution

Table 4 describes the marital status –wise distribution of respondents. Among the 119 scholars, 102 respondents (85.71429%) are unmarried whereas the remaining 17 (14.28571%) are married during the period of study. The result shows that the majority of the respondents of Periyar University belong to the category of unmarried who use online information.

Table 4: Marital status by the Respondents

Sl. No	Marital status	No of Respondents	Percentage (%)
1	Married	17	14.28571
2	Unmarried	102	85.71429
Total		119	100

5. Library Visit by the Respondents

It is inferred from the table 5 represents the respondents opinion on visiting the Periyar University Library. It is identified that out of 119 respondents, the majority of 73 (61.3%) respondents were visiting the library daily. One fourth of the respondents were visiting library weekly once. The minimum number of 5 (4.2%) respondents was visiting the library monthly once.

Table 5: Library Visit by the Respondents

Sl. No	Opinion	No of Respondents	Percentage (%)
1	Daily	73	61.3
2	Weekly	34	28.6
3	Fortnightly	7	5.9
4	Monthly	5	4.2
Total		119	100

6. Hours spend in the Library

Table 6 shows the respondents opinion on hours spends in the library. It is inferred that the maximum number of 69 (58%) of the respondents were spend 1 to 2 hours in the library. One third of (31) the respondents were spending less than one hour in the library. The least number of 19% of the respondents were spending more than 2 hours in the library.

Table 6: Hours spend in the Library

Sl. No	Opinion	No of Respondents	Percentage (%)
1	Less than 1 hr	31	26.1
2	1 to 2 hrs	69	58.0
3	More than 2 hrs	19	16.0
Total		119	100.0

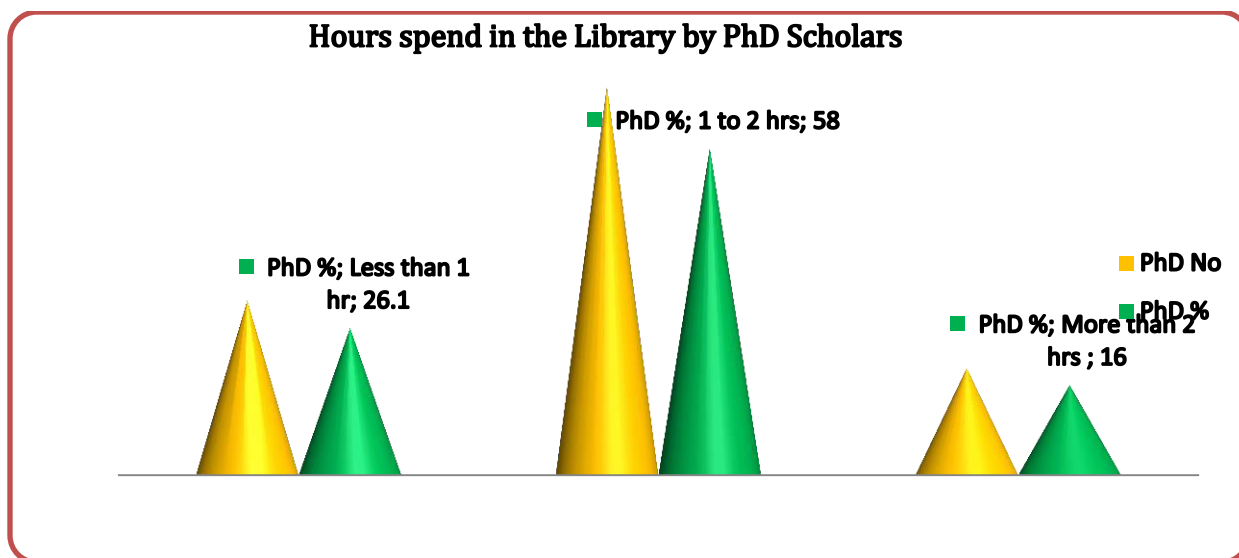

Figure 4: Hours spend in the Library by PhD Scholars

7. Purpose of using the Library

Table 7 depicts that the purpose of using the library by the respondents of Periyar university during the period of study. Based on the analysis which were taken by the researchers, out of 119 user community, the major part of 42 (35.29412%) respondents are using the library for research purpose and followed by 31 (26.05042%) users are using the library to prepare articles for publish on journals and conference proceedings whereas the least number of 8 (6.722689%) respondents are using the library to update their current information and research level.

Table 7: Purpose of using the Library

Sl. No	Purpose	No of Respondents	Percentage (%)
1	For career development	9	7.563025
2	To collect Subject information	11	9.243697
3	More convenient than print resources	18	15.12605
4	To prepare papers for journal / conference	31	26.05042
5	For research purposes	42	35.29412
6	To update current research	8	6.722689
Total		119	100

8. Problems while using the Electronic Resources

Table 8 shows the various problems faced by the respondents while accessing the library online resources. The problems such as lack of connectivity, slow speed, insufficient training, problems in downloading articles, lack of time and lack of awareness about Online Resources. it is noticed that out of 119 research scholars, the huge number of 35 (29.41176%) respondents are facing the problem while downloading the articles and followed by 21 (17.64706%) respondents had lack of time to use the resources and the least number of 12 (10.08403%) respondents are not aware about the online information which are available in the library.

Table 8: Ranking of problems while using the Online Resources

Sl. No	Problems	No of Respondents	Percentage (%)
1	Lack of connectivity	15	12.60504
2	Slow speed	19	15.96639
3	Insufficient training	17	14.28571
4	Problems in downloading articles	35	29.41176
5	Lack of time	21	17.64706
6	Lack of awareness about Online Resources	12	10.08403
Total		119	100

9. Level of satisfaction

Table 9 (fig.5) represents the level of satisfaction while using online resources in University Library during the period of study. Among the 119 respondents, 72 (60.5042%) users are fully satisfied to use the online resources and followed by 20 (16.80672%) respondents are satisfied using electronic resources and 16 (13.44538%) users are dissatisfied and remaining 11 responders did not report any comments.

Table 9: Level of satisfaction using University Online information

Sl. No	Rating	No of Respondents	Percentage (%)
1	Fully satisfied	72	60.5042
2	Satisfied	20	16.80672
3	Dissatisfied	16	13.44538
4	No Comments	11	9.243697
Total		119	100

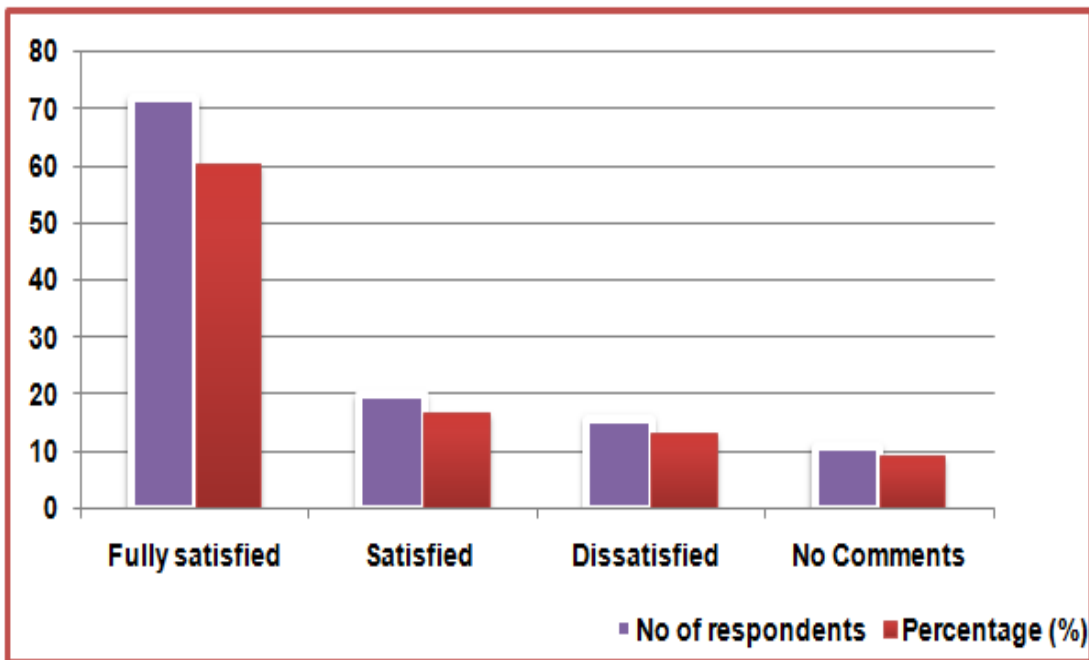

Figure 5: Level of satisfaction using University Online information

VII. FINDINGS

The findings of the results are found based on the analysis during the period of study as follows.

- It was found that 36.975% of respondents were Male and the rest of them were Female. It shows that Female respondents were interesting to involve in this study and ranked top.
- It was found that the majority of 51.2605% of respondents was in the age group of 31-35 and noticed that the average number of 33.33 % was identified overall study period.
- 32 percentages of respondents was from the School of Mathematics and ranked first and followed by School of Social Sciences with 23.52% of respondents and placed second place and School of Languages, School of Professional Studies, School of Life Sciences, School of Business Studies and so on.
- Among the 119 scholars, 102 respondents were unmarried whereas the remaining 17 were married during the period of study. The result shows that the majority of the respondents of Periyar University belong to the category of unmarried who use online information.
- It was identified that the majority of 61.3% of respondents were visiting the library daily. One fourth of the respondents were visiting library weekly once.

- Based on the analysis, 35.29% of respondents were using the library for research purpose and followed by 26.05% of users are using the library to prepare articles for publish on journals and conference proceedings.
- The huge numbers of 29.42% of respondents are facing the problem while downloading the articles and the least number of 10.08% of respondents are not aware about the online information which is available in the library.
- Among the 119 respondents, 60.50% of users are fully satisfied to use the online resources and followed by 16.81% of respondents are satisfied and only 13.45% of users are dissatisfied using electronic resources.

VIII. SUGGESTIONS

The following suggestions can be implemented with certain considerations for the users of the University Library.

1. It was found that more number of users mentioned that there is a slow speed of internet connections. So, majorities of the scholars suggested making high speed network for communication with intranet.
2. Training program for students at all levels to be provided how to use the e-resource facilities and more user awareness program on e-resource shall be conducted at regular intervals.
3. It is suggested that Library staff shall provide more guidance to the students for their study.
4. Computer Terminals should be increased with advanced digital system and more volume of journals and also University Library shall start more new Journal publication for all departments.

IX. REFERENCES

- [1] Nikam, K and Rashmi, BR. (2015). Use of E-Resources by the Academia of Speech and Hearing Discipline: A Study, *PEARL - A Journal of Library and Information Science*, 7 (4), 223-228.
- [2] Velmurugan, C. (2013). Use and user perception of electronic information resources: A case study of Siva Institute of Frontier Technology, India. *Chinese Librarianship: an International Electronic Journal*, 36. Retrieved from:
- [3] <http://www.iclc.us/cliej/cl36chandran.pdf>.
- [4] Kalbande, Dattatraya T., Shinde, P.A and Ingle R.N (2013). Use of E-Resources by the Faculty Members: a Case Study *International Research: Journal of Library & Information Science*, 3 (3), 459-469.
- [5] Biradar, B.S. et al. (2008). Use of Search Engines for Retrieval of Scholarly Information: A Case Study, *IASLIC Bulletin* 53 (4), 215-222
- [6] Mishra, O.P., Yadava, N., & Bisht, K. (2005). Internet Utilization Pattern of Undergraduate Students. *University News*, 43(13), 8-12.
- [7] Nyamboga, C M., Ongondo, M A & Wafula Ongus, R. (2004) Experiences in the Use of the Internet at Egerton University Library, Njoro-Kenya, *DESIDOC Bulletin of Information Technology*, 24 (5), 11-21.
- [8] Henley, Caroline, (2004) Digital reference services for young library users: a companion of four services), *Library Review*, 53 (1), 30- 36.



ISSN: 2347-1697

International Journal of Informative & Futuristic Research (IJIFR)

Volume - 4, Issue -4, December 2016

Continuous 40th Edition, Page No: 5822-5832

- [9] Carlson, Bethany and Reidy, Sharson (2004). Effective access: teacher's use of digital resources: research in progress, OCLC Systems & services. *International Digital Library Perspectives*, 20 (2), 65- 70.

To Cite This Article

Shankar, R. , Jayaprakash, M. (2016) : “Use And User Perception Of Online Information Resources Among The Research Scholars Of Periyar University, Salem (TN), India” *International Journal of Informative & Futuristic Research (ISSN: 2347-1697)*, Vol. 4 No. (4), December 2016, pp. 5822-5832, Paper ID: IJIFR/V4/E4/022.



Shankar. R, Dr. M. Jayaprakash :: Use And User Perception Of Online Information Resources Among The Research Scholars Of Periyar University, Salem (TN), India

5832

ATTITUDE OF PROSPECTIVE TEACHER EDUCATORS TOWARDS INCORPORATION OF ELECTRONIC LEARNING TECHNOLOGY IN TEACHER EDUCATION INSTITUTIONS: AN EMPIRICAL APPROACH

Paper ID	IJIFR/V4/ E4/ 007	Page No.	5833-5844	Subject Area	Education
Keywords	Attitude, E-Learning, Web-Based Learning, Digital Divide, Digital World, Virtual Classroom				

Dr. Shazli Hasan Khan

**Assistant Professor,
Maulana Azad National Urdu University
College of Teacher Education, Sambhal (U.P.)**

Abstract

Education system must respond to the changing needs of students and their teachers, just as business has reacted to its changing needs implementing employee training. Technological innovations are increasing the demand for altering the mode of transaction in the teaching and learning process and that in turn develop a significant impact on technology use expectations. It is the need of the hour that emerging technology of e-learning must be adopted in the teacher education curriculum of all universities in India. Online learning play a major role in the success of any academic program and can provide an environment where virtual learning classrooms are use to create interactive interfaces and real time software can monitor every response made by the learner. The term e-learning comprises a lot more than online learning, virtual learning, distributed learning, networked or web-based learning. E-learning would incorporate all educational activities that are cratered out by individuals or groups working online or offline and synchronously or asynchronously via networked or standalone computers and other electronic devices. The present study has been done so as to study the attitude of prospective teacher educators towards e-learning. Random sampling technique has been used in the selection of the sample of as many as 200 prospective teacher educators. The e-learning scale for measuring the attitude towards e-learning has been constructed and validated by Prakash, S. The scale is in the form of a Likert type and has been distributed to them and their responses were collected and computed according to the objectives framed. The findings of the study revealed that the prospective teacher educators showed a significantly favourable attitude towards e-learning.



I. INTRODUCTION

With the advent of computer and communication technologies, students in the field of higher education and particularly in distance education and online learning programs can receive learning materials online, join televised lectures, attend videos conference classes that link students and instructors from numerous geographic locations and participate in chat room discussions (Salman, 2012). The internet has developed into one of the most revolutionary technologies ever seen on the horizon of web-based technologies. It has brought revolution in business, commerce, communications and ultimately in higher education (Davis, 2002). Web based learning is an interactive net based learning system in which the World Wide Web technology is used as a learning environ. It provides people with instant access to online courses whether they are at home or at work. The web can be used as both a digital library and virtual; classroom.

Web-based learning makes intelligent use of media such as computer conferencing, electronic mail, Compact Discs-ROMs, Digital Videos Discs and the internet. These interactive technologies support many different types of capability such as: internet access to digital versions of materials unavailable locally, internet access to search and transactional services, interactive diagnostic or adaptive tutorials, interactive educational games, remote control access to local physical devices, personalized information and guidance for learning, support simulations or models of scientific systems, communication tools for collaboration with other students and teachers, tools for creativity and design virtual reality environments for development and manipulation data analysis, modeling or organization tools and applications, electronic devices so as to assist learners.

It is very surprising that there is a high level of awareness among Indian Corporate on the benefits of e-learning (electronic learning). Indian companies like Infosys, Wipro, NIIT, Tata Interactive etc. are harnessing the benefits of 31 billion global e-learning industries to impart training to their employees. In India the e-learning programs in relation to teacher education are still at an early and novice phase.

E-learning is a technology which supports teaching and learning via a computer web technology. E-learning is internet-enabled learning. E-learning provides faster learning at reduced costs, increased access to learning and clear accountability for all participants in the learning process. (Johnson, 2011). E-learning is a term that means something different to almost everyone who uses it. Some use the term to refer to packaged content pieces of information and others to technical infrastructures. Some think only of web-based self-study while others realize that e-learning can encompass real time learning and collaboration. Almost all agree that e-learning is of strategic importance.

We are all familiar with classroom-based learning which is face-to-face group learning led by an instructor or subject materials, their instructors and other learners from various locations and often at various times using network technologies. So by its nature, e-learning offers significantly flexibility as to when and how learning occurs. E-learning can include independent, facilitated or collaborative approaches to learning. Independent learning refers to each individual learner completing learning activities or modules on their





own schedule. There are several ways this can work. For example, a learner might complete a section of learning on-line then discuss key concepts via e-mail with the instructor or with classmates. Some of the more obvious benefits of e-learning include consistency of content, ease of customization, learner control, and reduction or elimination of travel costs to attend learning events. Consistency of content is achieved by the same learning being made available to anyone, anywhere, anytime with no degradation to the quality or effectiveness of the content or presentation. Though e-learning cannot exactly replace actual class on-line learning, it places certain effective tools on the teacher classroom hands. Multi-media rich contents and interactivity teacher presentations are more effective. Enabling content online also allows students to log on at a time conducive and convenient to them and they need not worry about missing important sections of a lecture. Another important benefit of e-learning is sharing teaching expertise among institutions. At a time when educational institutions are having a mushroom growth, with no correspondence increase in the number of experts available, e-learning tools can play an effective role bridging the knowledge gap. Enabling a teacher to deliver his lecture either from his private residence or from a classroom and broadcasting the content through satellite link or online would benefit institutions located in remote areas. The present study has been done to study the attitude of prospective teacher educators towards the use of electronic learning technology in their process of teaching and learning.

II. INCORPORATING E-LEARNING IN THE TEACHER EDUCATION PROGRAMS

There is immediate need to incorporate e-learning into the teacher education programs. The students opting for teaching as a profession need to be given a wider and extensive exposure to training by e-learning. Through e-learning programs they will not only acquire crucial concepts of the philosophy, psychology, sociology and gender-based studies and so on so forth, but e-simulations and e-games will give them practical exposure of the school and class environment. In the modern times improving the quality of education and training is the most critical issue in the sector of higher education. E-learning can enhance the quality of education by increasing learner motivation and engagement, by facilitating the acquisition of basic skills and by enhancing teacher training. Multimedia computer software that combines text, sound and colorful moving images can be used to provide challenging and authentic content that will engage student in the learning process. E-learning can increase learner motivation as it combines the media richness and interactivity with the opportunity to connect with real people and to participate in real world events. The transmission of basic skills and concepts that are the foundation of higher order thinking skills and creativity can be facilitated by e-learning through drill and practice. E-learning can support and scaffold the students for their own learning. And it also helps the students to clarify their doubts in any time. From this the students get wide knowledge and learning experience (Sivarajan, 2012).

E-learning can work in perfect synchronization with the teacher and the books to give the best to our students. All three of them i.e., e-learning, the computer factor; teacher,





the human factor and the books, the printed factor can strengthen, support and compliment each other in imparting holistic knowledge and training. It can surpass many of the pitfalls of regular classroom training such a boring slides, monotonous speech and two dimensional representations. The beauty of e-learning is that the new software allows the creation of very effective learning environment that can engulf the learning in the material. In this regard, an e-teacher as to adapt to continues professional development in the educational use of technology. In this sense, teachers have to be ready to make use of the possibilities that ICT offer, such a different learning contexts, focused on the students, presenting them with several types of interaction, offering different degrees of control of their own learning an promote collaborative tasks. Hence the e-teacher need to (i) Look at the subject content in a new way and re-think and adapt innovative course delivery. (ii) Gain computational proficiency that there is understanding of both its strength and its weakness (iii) Develop positive attitude towards e-learning (iv) Encourage students to set their own objectives and agendas (v) Understanding of different learning styles of students. E-learning creates a learning environment which is characterized by SMILE, an acronym for simple, motivating, interactive and learner centric environment. SMILE blends the best of both the words--- classroom learning and networked enabled learning (Sagar & Bhat, 2007).

III. LANDMARK E-LEARNING INITIATIVES IN THE CONTEXT OF INDIAN HIGHER EDUCATION

Realizing the importance of e-learning, UGC organized a dialogue on “*Enhancing Higher Education through e-learning*” in collaboration with the Commonwealth of Learning (COL), Vancouver in November, 2003 at New Delhi. The dialogue was attended by Vice-Chancellors of some selected Indian universities, heads of UGC’s national centers, and experts from COL an outside India. One of the recommendations of the group was that UGC should created a system to support the use of e-learning by all institutions of higher learning in India, in an ambitious timeframe to enhance quality in higher education through e-learning. The real impetus of e-learning came from the National Task Force on Information technology and Software Development constituted by the Prime Minister of India in 1998. The Task Force report presents the master plan that India has in place as a long term poly for capacity building of institutions, human resource development in IT related areas, and use of ICTs in higher education. The India Gandhi National Open University (IGNOU) responded to the recommendations of the Task Force with its Virtual Campus Initiatives (VCI) in 1999. Since then a number of initiatives are in operation in the country (Mishra & Sharma, 2005).

For enhancing the ICT skills of teachers, organizations like the NCERT (National Council of Educational Research and Training), and the NCTE (National Council for teacher Education) etc. has been launching schemes from time to time. Recently, NCTE has also launched a new project for integrating technology in education: the XPEDITTE (X-elerated Professional Development in the Integration of technology in Teacher Education) project in collaboration with Intel® Teach Program. The Intel Teach program is a globally acclaimed program that is being implemented in about 40 countries worldwide. It aims to



Dr. Shazli Hasan Khan :: Attitude Of Prospective Teacher Educators Towards Incorporation Of Electronic Learning Technology In Teacher Education Institutions: An Empirical Approach



help classroom teachers learn how best to use technology so as to improve teaching and learning. This collaborative project aims to provide professional development in technology integration to all teacher educators across the country.

Drastic efforts have been made in the field of e-learning in the form of “*Brihaspati*”, an e-learning platform developed as an open source freeware which IIT, Kanpur has developed and is being used since January 2003 supported by Ministry of Communication and Information Technology, Government of India. Faculties are using this platform to post the lecture notes, handouts, and reference materials on the Intranet for supporting the classroom teaching, benefiting over 175 Universities/ institutes across India. The tool for virtual classroom is called “*Brihaspati*” and it is open source software that could be used by any university. This is a very user-friendly open source framework and could be effectively used to build-learning application.

Another project web-based training is the National Programme on Technology Enhanced Learning (NPTEL), which is being funded by the Ministry of Human Resources Development (MHRD) and was first conceived in 1999 to pave way for introducing multimedia and web technology to enhance learning of basic science and engineering concepts, was launched in September 2006. Significant infrastructure has been set up for production of video-based teaching material by the Indian Institute of Technology (IIT), Bangalore based Indian Institutes of Science (IISc) and Technical Teacher Training Institute (TTTI). ‘Vartalaap’ is a computer-based solution over a computer network that creates an environment modeled closely on a real-world classroom can also be mentioned.

In the early 1999, the Tamil Nadu Government announced its intention to establish a Tamil Virtual University designed to promote Tamil language, literature and culture internationally through the medium of Internet-linked computers. CDAC (Centre for Development of Advanced Computing) a Scientific Society of the Ministry of Communications and Information Technology, Government of India has launched e-Sikshak, an e-learning framework and is offering free computer courses in Telegu, a regional language over its portal. Another initiative is Net-varsity established in 1996 by NIIT for IT related areas and soft skills. EDUSAT or GSAT-3 was launched in September 2004 by the Indian Space Research Organization; India’s dedicated education satellite carries the capability of providing audio, video and data services to India through its national and regional beams. EDUSAT is primarily meant for providing connectivity to school, college and higher levels of education and also to support non-formal education including developmental communication. Today, more than 35,000 classrooms in the country are connected in the EDUSAT network providing high quality education to the students in remote and rural areas.

The Ministry of HRD in 2002 has set up a “*Consortia based subscription*”, to electronic resources for Technical Education system in India on the recommendations made by the expert group appointed by the Ministry. The consortium is named as the Indian National Digital Library in engineering Science and Technology (INDEST) consortium. The consortium subscribes to bibliographic databases for 38 leading engineering and



technological institutions in India including IIT (7), IIM (6) and a few other institutions directly funded by MHRD (Ahmad, 2009).

There are eight inherent paradoxes and dilemmas in the implementation process of the ICTs in various higher education settings worldwide viz., the differential infrastructure and readiness of different-type of higher education institutions to utilize the ICTs' potential; the extent to which the "old" distance/formal education technologies and the new ICTs replace teachings/learning practices in classrooms; the role of real problems, barriers and obstacles in applying new technologies; the impact of the ICTs on different student clienteles; information acquisition versus knowledge construction in higher education; cost considerations; the human capacity to adapt to new learning styles and the ability to conduct research in the face of the rapid development of the ICTs; and the organizational cultures of the academic and corporate worlds. In a survey on Current Status and trends of E-learning performed by Asian Development Bank (2004), India has been ranked between 3.0 to 3.9 on a 10 point scale of e-Readiness among Asian countries.

Four phases were conducted so as to implement ICTs or e-learning content in the classroom. The phases are (i) ICTs Literacy; (ii) The effective and efficient use of ICTs hardware and software for teaching-learning activities; (iii) Pedagogy based ICTs use (integration of ICTs in subject content, teaching, online e support, networking and management), and (iv) Adopt best innovative practices in the use of ICTs (Singh & Dahiya, 2007). There should be developed e-learning culture in the institutions of teacher education.

IV. OBJECTIVES OF THE STUDY

The objectives of the study designed for the present study are as following:

1. To study the prospective teacher educators attitude towards e-learning technology.
2. To study if there is any significant difference in attitude towards e-learning technology between the male and female prospective teacher educators.
3. To study if there is any significant difference in attitude towards e-learning technology between the prospective teacher educators studying in the colleges of teacher education located in the urban areas and in the rural areas.
4. To study if there is any significant difference in attitude towards e-learning technology between the prospective teacher educators residing in the urban areas and in the rural areas.
5. To find out if there is any significant difference in attitude towards e-learning technology
6. Between the prospective teacher educators study through English medium of instruction and those studying with Hindi as medium of instruction.
7. To find out if there is any significant difference in attitude towards e-learning technology between the prospective teacher educators belonging to the arts group and to those who belong to the science group.

8. To find out if there is any significant difference in attitude towards e-learning technology between the prospective teacher educators who are residing in their own residences and those who are living in boarding houses.
9. To find out if there is any significant difference in attitude towards e-learning technology between married and unmarried prospective teacher educators.
10. To study if there is any significant difference in attitude towards e-learning technology between the prospective teachers educators who are under-graduate and post graduate in their major subjects.

V. HYPOTHESES OF THE STUDY

The hypotheses framed for carrying out the present investigation are as following:

1. There is no significant difference in attitude towards e-learning technology between the male and female prospective teacher educators.
2. There is no significant difference in attitude towards e-learning technology between the prospective teacher educators studying in the colleges of teacher education located in the urban areas and in the rural areas.
3. There is no significant difference in attitude towards e-learning technology between the prospective teacher educators residing in the urban areas and in the rural areas.
4. There is no significant difference in attitude towards e-learning technology between the prospective teacher educators studying through English as medium of instruction and those studying with Hindi as medium of instruction.
5. There is no significant difference in attitude towards e-learning technology between the prospective teacher educators belonging to the arts group and their counterparts in science group.
6. There is no significant difference in attitude towards e-learning technology between the prospective teacher educators who are residing in their own residences and those who are living in boarding houses.
7. There is no significant difference in attitude towards e-learning technology between married and unmarried prospective teacher educators.
8. There is no significant difference in attitude towards e-learning technology between the prospective teacher educators who are under-graduate and post graduate in their major subjects.

VI. METHODOLOGY OF THE STUDY

A normative survey method has been employed in the present study. The investigator visited seven Teachers training colleges located in Aligarh district and collected data from the prospective teacher educators studying these colleges. Most of these colleges were self-financed colleges.

6.1 Sample

A sample of 190 prospective teacher educators was selected through random sampling technique from seven colleges of teacher education in Aligarh district.

6.2 Tool Used

The tool used for the present study was ‘Attitude Towards e-Learning Scale’ by Prakash. S. (2011) was used in carrying out the present investigation. The tool was constructed and validated by Dr. Prakash. S. The scale is a five point scale and it consists of twenty four statements (Fifteen positive statements and nine negative statements). Each statement have the five options, namely; ‘Strongly Agree’, ‘Agree’, ‘Undecided’, ‘Disagree’ and ‘strongly disagree’. The response of the subjects was scored by using the numerical values or arbitrary weights to the items. The statements were having the scoring as 5,4,3,2 and 1 for the responses ‘Strongly Agree’, ‘Agree’, ‘Undecided’, ‘Disagree’ and ‘Strongly Disagree’ respectively for the positive statements and the scoring procedure is reversed for the negative statements. Higher the score indicates the favourable attitude towards e-learning. The scale used in the study, in order to measure the prospective teacher educators attitude towards e-learning has construct validity. The scale has intrinsic validity as found by the author of this tool was 0.89 (Prakash, S. 2011). The reliability was found to be 0.78 by the split-half technique. The author finally calculated the reliability of the tool to be as 0.81 and the intrinsic validity as 0.90. The attitude towards e-learning scale has its validity as well as reliability.

6.3 Statistical techniques Used

The statistical techniques used were mean, standard deviation and ‘t’-test. The mean and standard deviation for the entire sample and its sub-samples were computed for attitude towards e-learning scores. The ‘t’- test of significance was used so as to find out the significance of the difference between the means of the attitude towards e-learning score. The data collected was finally calculated using the Statistical Package for Social Sciences (SPSS) version 11.5 and after the data analysis the results found are hereby give in the table 1.0.

VII. ANALYSIS OF THE DATA

The analysis of the data reveals the following results which are shown in the table 1.0 given:

Table -1: Mean and the SD of the attitude towards e-learning scores of the entire sample and its sub-samples

S.No.	Samples	Sub-Samples	N	Mean	SD	‘t’ – value	Significant at 0.05 level
1.	Entire Sample		200	104.74	6.500	15.03	Significant
2.	Gender	Male	105	104.28	6.406	1.05	Not significant
		Female	95	105.25	6.620		
3.	Locality	Rural area	140	104.94	6.474	0.63	Not significant
		Urban area	60	104.28	6.628		
4.	Residence	Rural area	132	103.26	6.52	1.05	Not significant
		Urban area	68	104.21	6.71		
5.	Medium of Study	Hindi Medium	127	105.63	6.42	0.11	Not significant
		English	73	103.71	6.44		

		Medium					
6.	Subject group	Arts group	120	102.68	6.58	0.29	Not significant
		Science group	80	105.32	6.27		
7.	Mode of Stay	Boarding house	31	104.79	6.62	0.29	Not significant
		Own Residence	169	1.4.63	6.23		
8.	Marital Status	Unmarried	135	104.35	6.21	0.31	Not significant
		Married	65	104.64	6.24		
9.	Educational qualification	Under-graduate	152	1.4.42	6.63	0.64	Not significant
		Post graduate	48	105.52	6.48		

VIII. FINDINGS OF THE STUDY

From the table 1.0 it can be seen that present study has the following significant findings:

1. The prospective teacher educators show highly favorable attitude towards e-learning, as it can be seen from the table 1.0 for the entire and also for the sub-samples.
2. There is no significant difference in the attitude towards e-learning between the male and female prospective teacher educators. The hypothesis that there is no significant difference between the male and female prospective teacher educators stands accepted.
3. There is no significant difference in the attitude towards e-learning between the prospective teacher educators studying in the education colleges located in the urban and rural areas. The hypothesis that there is no significant difference in attitude towards e-learning technology between the prospective teacher educators residing in the urban areas and in the rural areas is accepted.
4. There is no significant difference in attitude towards e-learning technology between the prospective teacher educators studying through Hindi medium and in English as medium of instruction. The hypothesis that there no significant difference in attitude towards e-learning technology between the prospective teacher educators studying through Hindi medium and in English as medium of instruction is accepted.
5. There is no significant difference in attitude towards e-learning technology between the prospective teacher educators belonging to the arts group and their counterparts in science group. The hypothesis that there is no significant difference in attitude towards e-learning technology between the prospective teacher educators belonging to the arts group and their counter-parts belonging in science group is accepted.
6. There is no significant difference in attitude towards e-learning technology between the prospective teacher educators who are residing in their own residences and those who are living in boarding houses. The hypothesis that there is no significant difference in attitude towards e- learning technology between the prospective teacher educators who are residing in their own residences and those who are living in boarding houses stands accepted.

7. There is no significant difference in attitude towards e-learning technology between the prospective teacher educators who are married and unmarried. The hypothesis that there is no significant difference in the attitude towards e-learning technology between the prospective teacher educators who are married and unmarried stands accepted.
8. There is no significant difference in attitude towards e-learning technology between the prospective teachers educators who are under-graduate and post graduate in their major subjects. The hypothesis no significant difference in attitude towards e-learning technology between the prospective teacher educators who are under-graduate and post graduate in their major subjects stands accepted.

IX. SUGGESTIONS

The following are the suggestions for effective use of e-learning technology in teacher education institutions:

1. It is the teachers who are essential players in promoting quality education and no education reform is likely to succeed without the active participation and ownership of teachers. Teacher must be able to incorporate e-learning with the traditional learning and competent enough in web-based teaching
2. Teachers must change their mindset and accept a new teaching paradigm that is from teaching to facilitating and managing learning rather than disseminating of information.
3. Institutions of higher learning need to upgrade their teachers by offering re-training programmes on e-learning. Teacher Training institutions must develop competencies among teacher trainees in use of off-line e-resources and on-line resources and also in blended mode. Blended learning environments allow the pupil teachers to take part in both synchronous and asynchronous learning, overcoming barriers of communication, time and distance. The teacher training programme can have major lacunae if the teaching pedagogy is not matched with the learning environment.
4. There is a need to revise Teacher Education curriculum as well as curriculum in different disciplines of higher education in the light of technological advancement.
5. High quality learning materials developed for standard curriculum areas will provide a consistent and enhanced learning environment. E-content should be created in a format that will allow its utilization across various e-learning technology platforms. It is equally important to make certain that the content provided is consistent with the learning methodologies in use at various institutions and thus being more likely to result in successful learning (Greenagel, 2002).
6. Establishment of an e-learning consortium including member education institutions to offer e learning programmes without duplicating efforts and promoting sharing of e-resources.
7. Accreditate online learning courses and programmes to provide them social recognition. There is a wide disparity in the use of e-learning in India in rural and

urban areas. Further, where the facilities are available, the same are not being fully utilized. Proper feedback information at the Government bodies coordinating and controlling higher education and training is imperative in the management of the problem of 'digital divide' in academic institutions (Ahmad, 2004).

8. E-learning materials should also be available in various regional languages. There must be some 'reward system' for teachers incorporating e-learning tools in their teaching-learning process. There is an urgent need to promote researches on the various aspects of e-learning. Action researches may be a boon in this direction.

X. EDUCATIONAL IMPLICATIONS

E-learning has been used effectively in teacher educational institutions. Students enrolled on many courses in many institutions now find that they have web access to the lecture notes and selected digital resources in support of their study, they have web access to the lecture notes and selected digital resources in support of their study, they have personalized web environments in which they can join discussion forums with their class or group, and this new kind of access gives them much greater flexibility of study.

The 'digital divide' as it related to education is not so much about hardware or money but about 'attitude' to learn that will ultimately bring about relevant and global 'cultural changes' in both education and society associated with the ICT revolution. When any new technology emerges, teacher is charged to be able to use it without exception. But the fact is, not all people who work as teachers will be open minded with the new technology. However, e-learning demands a certain level of skills on the behalf of teachers and students both. Sometimes even highly educated teachers lack necessary computer and internet skills. Teacher education institutions must invest in training their teachers in necessary computer competency skills. This will boost teacher's self-efficacy which will have a positive defect on teaching-learning and promote acceptance of e-learning. Teacher education institutions must provide supportive environment, incentives and technical help to encourage e-learning. With a good strategy and promotion, the implementation of e-learning in teacher education institutions will be successful. E-learning is a large and growing market with great potential in teacher education. In order to maximize this potential, e-learning implementation should endeavor to satisfy the needs and concerns of all stakeholders as much as possible. Use of e-learning in teacher education has the following advantages: lower costs, time saving, flexibility, faster response, greater effectiveness, better morale, greater competitiveness and easy access to information and resources.

E-learning environments increasingly serve as important infrastructural features of universities that enable teachers to provide students with different representation of knowledge and to enhance interaction between teachers and students and amongst students themselves (Mahizadeh, 2008). In other words, teachers' use of e-learning environments can be explained to a high extent by their perceptions of the added value of these environments, which in turn are substantially influenced by their opinions about web-based activities and computer-assisted learning.

XI. CONCLUSION

Teacher education in view of globalization cannot afford to remain indifferent and unresponsive to the usefulness and benefits of e-learning. The spectrum of e-learning with its mind boggling progression has exercised a well discernable shift from formal schooling to de-schooling and to electronic schooling. With collaborative tools e-learning is moving virtual classes and virtual communities where the old methods of practice and test have melted into new interactive teaching-learning methodologies. A judicious blend of both traditional and virtual learning environment with special attention to students' needs and satisfaction can create constructive and creative learners, teaching community and learned society in India. The present investigation revealed that the prospective teacher educators studying in various teacher training colleges of Aligarh district were found to have a favourable attitude towards e-learning technology. The various demographic variables taken such as gender, locality of the college, residence of the prospective teacher educators, Medium of study, subject group, Mode of stay, marital status and educational qualification does not affect the prospective teacher educator's attitude towards e-learning technology. Thus, it can be seen from the above investigation that prospective teacher educators should also try to develop a favourable attitude towards e-learning in the prospective student teachers as well as among the teachers who are involved in using and incorporating the technology in the classroom.

XII. REFERENCES

- [1] Ahmad, Nighat (2004). E-readiness in Education. *University News*, 42 (13), 12-19.
- [2] Ahmad, B. (2009). Electronic Information Resources and Services in Agriculture. A Study. *University News*, 47 (27), 1-9.
- [3] Allen, L. Edward (1957). Techniques of attitude scale construction, *Appleton-century Crafts*, Inc., New York.
- [4] Best, John, W (2010). Research in Education, *Prentice Hall of India Pvt. Ltd*, New Delhi.
- [5] Davis, J (2002). E-learning in U.K. higher education, AUA USA/Canada Study visit 2002, <http://avavisit.open.ac.UK/themes>.
- [6] Garret, H.E., (1973). Statistics in Psychology and Education, Vakils, Feffer and Simons Ltd. Mumbai.
- [7] Greenagel, F.L. (2002). *The Illusion of e-learning: why we are missing out on the promise of technology*. Retrieved July, 10, 2009, from <http://www.guidedlearning.com/illusions.pdf>.
- [8] Mahdizadeh et al. (2008). Determining Factors of the Use of E-learning Environments by University Teachers. *Computers & Education*, 51 (1), 145-154, Retrieved on Jan. 24, 2009, from www.eric.ed.gov/.
- [10] Mishra, S & Sharma, R.C. (2005). Development of e-learning in India. *University News*, 43 (11), 9-15.
- [11] Salman, G (2012). E-Tivities: The Key to an active online learning, Kogan Page, Limited.
- [12] Sagar, A.V.; Bagga, R.K. (2007). SMILE-Learning Strategy for the Digital Age. *University News*, 45 (33), 10-20.
- [13] Srivastava, D.K. & Bajpai, N (2005). E-learning: A New Way of Education. *University News*, 43, (26), 12-15.

To Cite This Article

Khan, H.S. (2016) : "Attitude Of Prospective Teacher Educators Towards Incorporation Of Electronic Learning Technology In Teacher Education Institutions: An Empirical Approach" *International Journal of Informative & Futuristic Research (ISSN: 2347-1697)*, Vol. 4 No. (4), December 2016, pp. 5833-5844, Paper ID: IJIFR/V4/E4/007.

FOOD CONSUMPTION PATTERN OF SALTPAN WORKERS IN THOOTHUKUDI DISTRICT OF TAMIL NADU

Paper ID	IJIFR/V4/ E4/ 024	Page No.	5845-5853	Subject Area	Food Science and Nutrition
Keywords	Saltpan Workers, Food Consumption Pattern, Mean Food Intake				

1 st	Mathuravalli. S.M.D	Associate Prof essor Department of Food Science and Nutrition Holy Cross Home Science College, Thoothukudi, Tamil Nadu
2 nd	Dr. Sr. Mary S.A	Associate Professor, Department of Home Science, Fatima College, Madurai, Tamil Nadu
3 rd	Dr. B.Geetha	Associate Professor, Department of Zoology, V.O.C.College, Thoothukudi, Tamil Nadu

Abstract

The study was conducted to find out the food consumption pattern of saltpan workers in Thoothukudi district of Tamil Nadu. A total of 200 saltpan workers, including both men and women, were selected randomly from the saltpan areas of Veppalodai, Pattinamaruthoor, Tharuwaikulam and Mullakadu. A pretested interview schedule was used to elicit the various information from the saltpan workers. The result revealed that rice as the staple food and it was consumed daily by all the respondents and wheat in their diet was more frequent than ragi. The majority of the families utilized red gram dhal once in a week and black gram dhal occasionally. The green leafy vegetables such as agathi, araikeerai, drumstick greens and amaranth were consumed occasionally because of their busy schedule to prepare it. All the respondents consumed onion, tomatoes and chillies daily, but fruits mainly banana and seasonal fruit (mango) occasionally. It was also observed that most the respondents taking breakfast and lunch not in time and few of them were skipping lunch due to the urge in finishing their allocated work in time. Almost all the respondents were consumed milk daily with tea or coffee twice in a day in the workplace Among the non-vegetarian foods, egg was consumed frequently, but few of the respondents were consumed chicken occasionally for the sake of their children especially

during special occasions. Regular consumption of low value fishes, especially anchovies, sardines, mackerel, barracudas (small), threadfins, crab (small), etc., was noticed in all the respondents either in the form of fresh or dry. All the respondents consumed palm oil, but groundnut oil and vanaspathi were included occasionally, especially during festivals. Poor selection and utilisation of foodstuffs noticed among the selected respondents might be due to their poor educational background, lack of exposure and awareness on the importance of nutrition for health.

I. INTRODUCTION

Thoothukudi district occupies a very important place in the history of the salt industry in India because of its geographic location and other favourable factors. The North East Monsoon is comparatively weak, dry climate is fair and the average rainfall in Thoothukudi district provides an uninterrupted manufacturing of salt for 8 to 9 months in a year. The salt industry is the main backbone of economic development of the district. It is the cluster group of industry of Thoothukudi district and was extended in an area of 20,000 acres with production of 17.12 Lakhs M.T (Madhu, 2006). The saltpans are spread over 22 villages in Thoothukudi district and it has the highest number of salt workers in the state and generates the maximum production of salt in Tamil Nadu. These saltpans are developed in lands leased either by the Central or by the State Government. The Central Government leased lands are by and large taken up by the Salt Producers' Cooperative Societies and private producers. The State Government lands are leased to the Tamil Nadu Salt Corporation. Apart from this, about 8,000 acres of private lands are converted into saltpans (Vrutti, 2007). There are about 2000 small scale salt manufacturers and traders in Thoothukudi district. The salt workers of this district are facing many problems related to their nutrition and health conditions. The present study was taken up to measure the food consumption pattern of saltpan workers in Thoothukudi district of Tamil Nadu.

II. METHODOLOGY

Thoothukudi district was selected for the study because the salt industry is the major work in this district. The study was carried out in 4 saltpan areas, namely Veppalodai Pattinamaruthoor, Tharuvaikulam and Mullakadu. The average distance of the selected saltpans was ranged from 10 to 40 km. The sample for the study consisted of 200 saltpan workers, including both sexes in the age range of 20 to 60 years and were selected by using random sampling method. The saltpan areas selected had similar socioeconomic status, working and living conditions and had comparable access to the worksites. Local Council Members and Guides helped in identifying the residences of saltpan workers and worksites. The interview schedule was pre- tested with 20 saltpan workers of non-sampling areas before commencing the actual investigation to screen for potential problems in the interview schedule and to get an idea about responses to the questions. The pre-test helped to restructure the interview schedule with necessary modifications and to finalize the interview schedules.

2.1. 24-hour recall method

The data on home dietary intake were collected through a 24-hour recall method from each of the respondents for three consecutive days. To know the actual intake of foods, the survey was conducted only once during the study period, excluding holidays, festivals and other special occasions. The intake of food was assessed by 24-hour recall method using a set of pre-standardized vessels. The quantities of various food items consumed for each meal (breakfast, lunch, snack items and dinner) by each respondent were obtained by interviewing the respondents. The standardised sets of simple vessels were used to obtain the actual amount of cooked foods consumed by each respondent. Food eaten by each individual was asked by showing the standardised vessels and noted the measurements carefully. The respondents were asked to repeat the recall of menu items a couple of times and the collected data were cross-checked.

Leftover portions and amounts of foods wasted were also considered in order to know the exact amount of food consumed by the respondents. Information was collected on how often certain foods were eaten. Any food eaten in between breakfast, lunch, tea or dinner was also recorded by recall method. The water and salt were usually not recorded which are not always regarded as food. Data on consumption of coffee, tea and other beverages were also included. The amount of raw ingredients used for each preparation was calculated by adopting the method recommended by Ryan *et al.* (1984) and Swaminathan (1991). The nutrients such as energy, protein, fat, calcium, iron, beta carotene and sodium supplied through the diet were calculated and compared with the ICMR values (Gopalan *et al.*, 2012).

III. RESULTS AND DISCUSSION

It could be seen from the table-1 that the rice being the staple food and it was consumed daily by all the saltpan workers (100%). The inclusion of wheat in the diet was more frequent (100%) than ragi and semolina which were used occasionally by 31 and 9 per cent of the respondents respectively. Most of the respondents stated that the wheat was consumed in the form of dosa.

Table 1: Frequency of consumption of cereals

Cereals	Frequency of consumption				Total	Percentage
	Daily	Alternate days	Once in a week	Occasionally		
Rice	200 (100%)	0	0	0	200	100
Wheat	0	0	108 (54%)	92 (46%)	200	100
Ragi	0	0	0	62 (31%)	62	31
Semolina	0	0	0	18 (9%)	18	9

As it could be evident from the table -2 that of the pulses, about 14 percent of the families were used red gram dhal once in a week while 9 percent of the respondents were utilized the black gram dhal once in a week. But most of the saltpan worker’s family used red gram dhal and black gram dhal occasionally by 86 and 71 per cent respectively. The black gram dhal

was consumed either in the form of idly or dosa. The roasted Bengal gram dhal was consumed occasionally (88%).

Table 2: Frequency of consumption of pulses

Pulses	Frequency of consumption				Total	Percentage
	Daily	Alternate days	Once in a week	Occasionally		
Red gram dhal	0	0	28 (14%)	172 (86%)	200	100
Black gram dhal	0	0	38 (19%)	142 (71%)	180	90
Bengal gram dhal	0	0	0	200 (100%)	200	100
Bengal gram dhal (roasted)	0	0	24 (12%)	176 (88%)	200	100
Green gram	0	0	0	126 (63%)	126	63
Cowpea	0	0	0	18 (9%)	18	9

The inclusion of green gram and the cowpea was analysed and it was noted that 63 and 9 percent of the saltpan worker's families respectively used it occasionally. According to Pandey and Neerubala (2013), the consumption of large quantities of cereals and relatively negligible quantities of pulses in the diets, although protective food was consumed in meagre quantities. The frequency of consumption of vegetables is given in the table -3. It is observed that of the vegetables, the respondents were consumed brinjal and drumstick once in a week by 14 and 37 percent respectively. About 86 and 63 per cent of saltpan workers were consumed brinjal and drumstick occasionally. All the selected respondents were consumed ladies finger rarely. Few workers were rarely included cluster beans, chow-chow, beans and gourd varieties in their diet. The saltpan workers were using the vegetables such as cluster beans, chow-chow, beans and gourds by 34, 11, 16 and 9 per cent respectively. Other vegetables such as tomato and green chillies were consumed once in a week by 26 and 38 percent and occasionally by 74 and 62 per cent of the respondents respectively.

Table 3: Frequency of consumption of vegetables

Vegetables	Frequency of consumption				Total	Percentage
	Daily	Alternate days	Once in a week	Occasionally		
Brinjal	0	0	28 (14%)	172 (86%)	200	100
Drumstick	0	0	74 (37%)	126 (63%)	200	100
Ladies finger	0	0	0	200 (100%)	200	100
Cluster beans	0	0	0	68 (34%)	68	34
Chow-chow marrow	0	0	0	22 (12%)	22	11
Beans	0	0	0	32 (16%)	32	16
Gourd	0	0	0	18 (9%)	18	9
Tomato	0	0	52	148 (74%)	200	100
Green chillies	0	0	76	124 (62%)	200	100

From the analysis it was found that the respondents were included green leafy vegetables in the form of vada and bonda which were purchased and eaten in the working place. The green leafy vegetable such as araikeerai, drumstick greens and amaranth were consumed

once in a week and occasionally by the saltpan workers as it is evident from the table -4. Green leafy vegetables being the cheapest and nutritious protective foods were used once in a week and occasionally. Difficulty in preparing breakfast because of their busy schedule and unaware of the nutritious food identified were the reason for the low inclusion of green leafy vegetables in their daily diets.

Table 4 : Frequency of consumption of green leafy vegetables

Green leafy vegetables	Frequency of consumption				Total	Percentage
	Daily	Alternate days	Once in a week	Occasionally		
Agathi	0	0	0	108 (54%)	108	54
Araikeerai	0	0	12 (6%)	168 (84%)	180	90
Drumstick Greens	0	0	24 (12%)	136 (68%)	160	80
Amaranth	0	0	4 (2%)	76 (38%)	80	40

It was noticed that agathi was consumed occasionally by 54 percent and few of the saltpan workers never consumed other greens except drumstick greens. Most of the households had got drumstick and drumstick leaves from their own backyards or from neighbour's trees. Very few women purchased drumstick and the greens from the local vegetable market. It was also noticed that the saltpan workers were avoiding greens during nights. According to Pandey and Neerubala (2013), increased household income was associated with higher intake of iron from meat, poultry and all animal sources, but in the present study, low income decreased the purchasing power of households. It could be seen from the table -5 that all the respondents consumed onion, but 20 and 7 per cent of the families consumed onion daily and alternate days respectively. About 36 percent of respondents consumed it once in a week and 37 percent of the saltpan workers consumed it occasionally. Most of the saltpan workers were utilised roots and tubers such as potato, carrot, yam and radish once in a week and occasionally by 56, 26, 18, and 24 percent respectively.

Table 5 : Frequency of consumption of roots and tubers

Roots and tubers	Frequency of consumption				Total	Percentage
	Daily	Alternate days	Once in a week	Occasionally		
Onion	40 (20%)	14 (7%)	72 (36%)	74 (37%)	200	100
Potato	0	0	36 (18%)	112 (56%)	148	74
Carrot	0	0	14 (7%)	52 (26%)	66	33
Yam	0	0	24 (12%)	36 (18%)	60	30
Radish	0	0	0	48 (24%)	48	24

The table - 6 provides the details of frequency of consumption of fruits by the families of saltpan workers. It could be seen that most of the respondents were included fruits occasionally. About 64 per cent of saltpan workers were consumed banana occasionally. Lime juice was taken occasionally (62%) and only 7 percent of the respondents were consumed grapes occasionally. This might be due to the increased cost of fruits.

Table 6 : Frequency of consumption of fruits

Fruits	Frequency of consumption				Total	Percentage
	Daily	Alternate days	Once in a week	Occasionally		
Banana	0	0	0	128 (64%)	128	64
Lime	0	0	56 (28%)	124 (62%)	180	90
Grapes	0	0	0	14 (7%)	14	7

About 13 percent of the respondents consumed milk daily, whereas, 12 and 15 per cent once in a week and occasionally. The quantity of inclusion of milk was very less even though the frequency of consumption of coffee and tea was frequent. Few of the respondents had taken only black coffee or black tea (without milk). During the hot season they were using milk in the form of buttermilk. Buttermilk was used daily by 10 percent respondents; alternate days by 6 percent, once in a week by 24 per cent and occasionally by 30 percent.

Table 7: Frequency of consumption of milk and milk products

Milk and Milk products	Frequency of consumption				Total	Percentage
	Daily	Alternate days	Once in a week	Occasionally		
Milk	26 (13%)	24 (12%)	30 (15%)	0	80	40
Buttermilk	20 (10%)	12 (6%)	48 (24%)	60 (30%)	140	70

The table-8 shows the details of consumption of egg and other flesh foods. It could be seen that the inclusion of egg (42%), chicken (56%) and mutton (11%) in their diet were mostly occasional, especially during festivals. This might be due to the increased cost of flesh foods and low purchasing capacity of the families. Chicken and mutton were never used by 19 and 85 percent of the respondents respectively. All the respondents were used fish in their diets, mostly daily (62%).

Table 8: Frequency of consumption of egg and other flesh foods

Egg and other flesh foods	Frequency of consumption				Total	Percentage
	Daily	Alternate days	Once in a week	Occasionally		
Egg	0	60 (30%)	36 (18%)	84 (42%)	180	90
Chicken	0	0	50 (25%)	112 (56%)	162	81
Mutton	0	0	8 (4%)	22 (12%)	30	15
Fish	124 (62%)	46 (23%)	30 (15%)	0	200	100

About 96 percent of the respondents used palm oil daily. Groundnut oil and vanaspathi were never purchased by 76 and 21 per cent of the respondents because it is considered as costlier when compared to palm oil. However, they included dalda and gingelly oil occasionally or during festivals to prepare snack items as it could be seen from the table -9.

Table 9: Frequency of consumption of fats and oils

Fats and oils	Frequency of consumption				Total	Percentage
	Daily	Alternate days	Once in a week	Occasionally		
Palm oil	192 (96%)	0	8 (4%)	0	200	100
Groundnut oil	0	0	0	48 (24%)	48	24
Dalda	0	0	0	158 (79%)	158	79

The table-10 indicates that most of the respondents were included sugar in tea or coffee daily and once in two days. It was noticed that all the respondents were included sugar daily or alternate days. Jaggery is being considered as a nutritious and cheapest ingredient and the respondents were included in their main meal or beverages.

Table 10: Frequency of consumption of sugar

Sugar	Frequency of consumption				Total	Percentage
	Daily	Alternate days	Once in a week	Occasionally		
Cane sugar	172 (86%)	28 (14%)	0	0	200	100
Jaggery	72 (36%)	72 (36%)	56 (28%)	0	200	100

The saltpan workers were consumed breakfast from roadside food shops before going for the work. Mainly idly and aapam with coconut chutney was purchased and consumed by the respondents at a cheaper price or they bring previous days left overs as breakfast and lunch. The poor selection and utilisation of foodstuffs noticed among the selected respondents might be due to their poor educational background, lack of exposure and awareness of nutrition. Respondents engaged in field work and head loading activities in the worksite near or far away from their place, preferred to carry cooked-rice or in the form of kanji (cold rice from previous days left over), previous day's curry or chutney (thuvaiyal) as they think that such diet prevent them from getting thirsty and reduces the demand of water which is to be carried with them.

3.1. Mean Food Intake Of The Selected Saltpan Workers

The mean food intake of the selected saltpan workers is presented in the table -11. It could be observed that the cereals formed the bulk portion of the dietaries in the selected men and women workers studied. The average cereal consumption was found to be 396g and 220g by the men and women saltpan workers respectively. A deficit of 57.40 and 45.80 percent was observed in cereal consumption of men and women workers when compared with the suggested quantities (690 gm) of ICMR (2010). Similarly, the mean intake of pulses was observed to be 34g and 22g among the men and women workers respectively. On an average, 52.40 and 44 percent deficit in pulse intake was identified. Consumption of green leafy vegetables met only 27 percent and 18 percent of RDA. In general, the consumption of fruit was less among the saltpan workers. As far as the inclusion of other vegetables was

concerned, a deficit of 40 and 50 percent was noted among the men and women respondents working in the saltpans.

Table 11: Mean food intake of the selected saltpan workers

No.	Foods	Men			Women		
		RDA	Mean Actual Intake g/day	% RDA	RDA	Mean Actual Intake g/day	% RDA
1	Cereals (g)	690	396±23	57.4	480	220±65	45.8
2	Pulses (g)	65	34±6.5	52.4	50	22±9.7	44
3	GLV (g)	125	27±18.3	21.6	125	18±21.2	14.4
4	Fruits (g)	100	37±23.9	37	100	8±11.3	8
5	Other vegetables (g)	100	40±8.5	40	100	50±12.6	50
6	Roots & tuber (g)	100	52±5.3	52	100	30±6.5	30
7	Milk & milk products (g)	200	215±33.1	+107.5	200	32±75.9	16
8	Flesh foods (g)	45	29±3.2	64.44	35	25±5.9	71.4
9	Fats & oils (g)	45	49±5.9	+108.9	35	36±4.3	+102.88
10	Sugar & jaggery (g)	50	17±5.6	34	40	10±39	25.0

The intake of roots and tubers was 52gm and 30gm against the RDA 100 gm among the men and women workers. The mean intake of milk and milk products was 215g by the men, i.e., more than the RDA (15g), but 32g by the women workers. Inclusion of flesh foods by men workers was 64.44 percent and women salt workers were 71.40 percent. The consumption of fats and oils was more than 9 percent (49 gm) and 3 percent (36 gm) of RDA in respect of men and women workers. Inclusion of sugar and related products met 34 percent and 25 percent allowance among the men and women saltpan workers. In India a number of surveys conducted on dietary consumption revealed that the majority of the population depends on cereal based diet, because cereals being the cheapest source of calories contribute 70-80 percent of the total calories in the diet (ICMR, 2010).

IV. CONCLUSION

The result revealed that rice as the staple food and it was consumed daily and wheat in their diet was more frequent than ragi. The majority of the families utilized red gram dhal once in a week and black gram dhal occasionally. The green leafy vegetables were consumed occasionally because of their busy schedule. All the respondents consumed onion, tomatoes and chillies daily, but fruits like banana and seasonal fruit were consumed occasionally. Most the respondents taking breakfast and lunch not in time and few of them were skipping lunch. Almost all the respondents were consumed milk daily with tea or coffee twice or more in a day in their workplace. Among the non-vegetarian foods, egg was consumed frequently. Regular consumption of low value fishes was noticed in all the respondents either in the form of fresh or dry. All the respondents consumed palm oil, but groundnut oil and vanaspathi were included occasionally. Poor selection and utilisation of foodstuffs

noticed among the selected saltpan workers might be due to their poor educational background, lack of exposure and awareness on the importance of nutrition for health.

5. REFERENCES

- [1] Gopalan, C., Rama Sastri B.V. and S.C. Balasubramanian, Nutritive value of Indian Foods, revised and updated by Narasinga Rao and Y.G. Deosthale and K.C.Pant, National Institute of Nutrition, ICMR. Hyderabad, 2012, pp. 47-67.
- [2] ICMR, 2010, Nutrient requirement and recommended dietary allowances for Indians, National Institute of Nutrition, Hyderabad.
- [3] Madhu S R 2006, BOBP-IGO report on 'Socioeconomic status of workers in the salt industry' -The saga of India's salt workers
- [4] Pandey, P and Neerubala, 2016, Food consumption patterns of adult population in rural and urban areas of Faizabad District of Uttar Pradesh, India, International Journal of Science and Research (IJSR), Vol. (5) 2, pp, 2080-2084.
- [5] Online (<https://www.ijsr.net/archive/v5i2/NOV161620.pdf>) last assessed on 12/12/2016.
- [6] Ryan, J.G., P.D. Bidinger, N. Prahlad Rao and P. Pushpamma, 1984, The determinants of individual diets and nutritional status in six villages of Southern India, ICRISAT Research Bulletin No. 7, pp. 77-78.
- [7] Swaminathan, M, Nutrition of industrial and agricultural workers, Handbook of Food and Nutrition, BAPPCO Publications, Bangalore, India, 1991, pp. 267 – 269.
- [8] Vrutti 2007, Situation analysis of salt workers in Tamil Nadu and developing project outline for improving their socioeconomic status, Livelihood Resource Centre, Bangalore, India. pp. 18-19.

To Cite This Article

Mathuravalli, S.M.D, Sr. Mary, S.A, Geetha, B. (2016): "Food Consumption Pattern Of Saltpan Workers In Thoothukudi District Of Tamil Nadu" International Journal of Informative & Futuristic Research (ISSN: 2347-1697), Vol. 4 No. (4), December 2016, pp. 5845-5853, Paper ID: IJIFR/V4/E4/024.

CUSTOMERS SATISFACTION LEVEL OF KARUR VYSYA BANK IN COIMBATORE DISTRICT

Paper ID

IJIFR/V4/ E4/ 025

Page No.

5854-5859

Subject Area

Commerce

Keywords

ATM, Customer Satisfaction, KVB, Awareness Level, Coimbatore City

1 st	Rajam	Associate Prof essor PG and Research Department of commerce Kongunadu Arts and Science College Coimbatore -TamilNadu, India
2 nd	R . Sakthivel	Assistant Professor, PG and Research Department of commerce Kongunadu Arts and Science College Coimbatore -TamilNadu, India

Abstract

A bank is a financial institution and a financial intermediary. It accepts deposits and channels those deposits into lending activities, either directly or through capital markets. A bank connects customers that have capital deficits to customers with capital surpluses. Due to their critical status within the financial system and the economy generally, banks are highly regulated in most countries. Karur Vysya Bank was started in the year 1916 in Karur, then a small textile town with a vast agricultural background, by two illustrious sons of the soil – Sri M.A. Venkatarama Chettiar and Sri Athi Krishna Chettiar. What started as a venture with a seed capital of Rs. 1.00 lakh has grown into a leading financial institution that offers a gamut of financial services to millions of its customers under one roof. The bank that carries with it a tradition of 100 years and yet is young enough to adapt itself to the rapidly changing scenario in the banking industry. This study has been conducted to measure the level of satisfaction of customers on the service quality of Karur Vysya bank. This study intends to analyze the satisfaction level and services of Karur Vysya bank, awareness level of customers and problems faced by the customers of Karur Vysya bank Based on the convenient sampling method, 500 respondents have been selected to conduct the interview in Coimbatore city.



I. INTRODUCTION

Banking in India originated in the last decades of the 18th century. The first banks were The General Bank of India, which started in 1786, and Bank of Hindustan, which started in 1790; both are now defunct. The oldest bank in existence in India is the State Bank of India, which originated in the Bank of Calcutta in June 1806, which almost immediately became the Bank of Bengal. This was one of the three presidency banks, the other two being the Bank of Bombay and the Bank of Madras. All these three banks were established under charters from the British East India Company. For many years the Presidency banks acted as quasi-central banks, as did their successors. The three banks merged in 1921 to form the Imperial Bank of India, which became the State Bank of India in 1955.

1.1 – Banking: An Overview

For the past three decades India's banking system has several outstanding achievements to its credit. The most striking is its extensive reach. It is no longer confined to only metropolitans or cosmopolitans in India. In fact, Indian banking system has reached even to the remote corners of the country. This is one of the main reasons of India's growth process. The government's regular policy for Indian bank since 1969 has paid rich dividends with the nationalization of 14 major private banks of India. The first bank in India, though conservative, was established in 1786. From 1786 till today, the journey of Indian Banking System can be segregated into three distinct phases. They are as mentioned below:

- Early phase from 1786 to 1969 of Indian Banks
- Nationalisation of Indian Bank Prior to Indian banking sector Reforms 1991.
- New phase of Indian Banking System with the advent of Indian Financial & Banking Sector Reforms after 1991.

1.2 - A Profile Of Karur Vysya Bank

Karur Vysya Bank was started in the year 1916 in Karur, then a small textile town with a vast agricultural background, by two illustrious sons of the soil – Sri M.A. Venkatarama Chettiar and Sri Athi Krishna Chettiar. What started as a venture with a seed capital of Rs. 1.00 lakh has grown into a leading financial institution that offers a gamut of financial services to millions of its customers under one roof. The bank that carries with it a tradition of 100 years and yet is young enough to adapt itself to the rapidly changing scenario in the banking industry.

1.3 - History Of Karur Vysya Bank

Commercial banking in India can boast of a history of about 200 years. Though one could trace the history of banking back to the 19th century, the beginning of the last century saw the birth of many banks in India, set up by people with vision, commitment and national spirit. The Karur Vysya Bank Limited, popularly known as KVB, one such endeavor, was set up in 1916 by two great visionaries and illustrious sons of Karur, the Late Shri M A Venkatarama Chettiar and the Late Shri Athi Krishna Chettiar to inculcate the habit of savings and provide financial assistance to traders and small agriculturists in and around Karur, a textile town in Tamil Nadu. Though the bank started with a seed capital of Rs.1 lakh, it has withstood innumerable changes and challenges in the past few decades and has

profitably emerged as one of the leading banks in India without compromising on its fundamentals. The bank is professionally managed and guided by the Board of Directors drawn from different fields with vision, experience, and knowledge and business acumen. Shedding its inherent regional flavour, the bank has now spread its wings far and wide with over 675 branches in 20 States and 3 Union Territories in order to gain a pan India presence. The bank has been conducting its affairs meticulously to conform to all the prudential norms and exacting statutory regulations. KVB has consistently maintained strong fundamentals with a higher percentage of Capital Adequacy Ratio than mandated by the RBI. KVB has also been generating profits and rewarding its stakeholders with handsome dividends since inception.

1.4 Scope of the Study

The present study titled as “Customers satisfaction level of Karur Vysya bank in Coimbatore district”. This study is confined to Coimbatore only. This study intends to analyze the satisfaction level and services of Karur Vysya bank, awareness level of customers and problems faced by the customers of Karur Vysya bank.

2. RESEARCH PROCEDURE

• **Data Collection**

Both primary and secondary data sources of data have been used for the study.

• **Area of the Study**

Area of the study is confined to the Coimbatore city.

• **Sampling procedure**

Based on the convenient sampling method, 500 respondents have been selected to conduct the interview in Coimbatore city. The convenient sampling is adopted due to the vast majority of scattered account holders of the bank in Coimbatore city.

3. OBJECTIVES OF THE STUDY.

- To study the socio economic profile of the respondents.
- To measure the level of satisfaction of customers on the service quality of Karur Vysya bank.

4. ANALYSIS AND INTERPRETATION

Table 1: Profile of the respondents

Factors	No. Of Respondents	Percentage
Gender		
Male	302	69.4
Female	198	30.6
Total	500	100
Marital Status		
Married	234	46.8
Unmarried	266	53.2
Total	500	100

Educational Qualification		
Sslc	94	18.8
Hsc	109	21.8
Graduate	268	53.6
Post Graduate	24	4.8
Others	5	1
Total	500	100
Occupation		
Govt Employees	32	6.4
Private Employee	129	25.8
Business People	107	21.4
Agriculturist	24	4.8
Student	62	12.4
Housewife	98	19.6
Other	48	9.6
Total	500	100

According to table number 1:

- Majority of the respondents (60.4 percent) were male. Only (39.6 percent) of the female are the accountholders in the sample;
- Majority of the respondents (53.2 percent) are unmarried and rest of them are married. However, there are no much differentiation between married and unmarried category of respondents in availing the services of Karur Vysya bank.;
- Most of them are graduates, one fourth of the sample respondents are having school education;
- Most of the sample respondents engage in private jobs (25.8 percent) , Business (21.4 percent) and government jobs (6.4 percent).Rests of them are students, agriculturist and house wives.

Table 2: Satisfaction level of the respondents regarding the services

Factors	Opinion	Number Of Respondents	Percentage
Various Banks Branches In Your Area	Highly Satisfied	125	25
	Satisfied	87	17.4
	Neutral	117	23.4
	Dissatisfied	103	20.6
	Highly Dissatisfied	68	13.6
Maximum Limit And Procedure For Depositing Money By Using Atm	Highly Satisfied	168	33.6
	Satisfied	111	22.2
	Neutral	76	15.2
	Dissatisfied	82	16.4
	Highly Dissatisfied	63	12.6
Number Of Atm Center Provided By	Highly	147	29.4

Your Bank In Your Area	Satisfied		
	Satisfied	109	21.8
	Neutral	113	22.6
	Dissatisfied	64	12.8
	Highly Dissatisfied	67	13.4
Only The Savings Bank Account Holder Is Eligible To Get Debit Card/Credit Card	Highly Satisfied	114	22.8
	Satisfied	137	27.4
	Neutral	59	11.8
	Dissatisfied	116	23.2
	Highly Dissatisfied	74	14.8
Maximum Amount That Can Be Availed Out Of Credit Card Is Fixed By The Bank Based On The Net Worth Of The Customer	Highly Satisfied	108	21.6
	Satisfied	153	30.6
	Neutral	117	23.4
	Dissatisfied	73	14.6
	Highly Dissatisfied	49	9.8
Nomination Facility Provided To The Account Holder	Highly Satisfied	96	19.2
	Satisfied	139	27.8
	Neutral	103	20.6
	Dissatisfied	127	25.4
	Highly Dissatisfied	35	7

Source: Primary Data.

V. FINDINGS AFTER ANALYSIS

- **Various banks branches in your area:** It is interpreted from the above table – 4.14 have a 25 % of respondent are highly satisfied in various banks branches. And 23.4 % are neutral, 20.6% are dissatisfied, 17.4% are satisfied and rest of them are highly dissatisfied
- **Maximum limit and procedure for depositing money by using ATM:** It is interpreted from the above table – 4.14 have a 33.6% of respondent are highly satisfied in Maximum limit and procedure for depositing money by using ATM. And 15.2% are neutral, 16.4% are dissatisfied, 22.2% are satisfied and rest of them are highly dissatisfied
- **Number of ATM centre provided by your bank in your area:**It is interpreted from the above table – 4.14 have a 29% of respondent are highly satisfied in Number of ATM centre provided by your bank in your area. And 22.6% are neutral, 12.8% are dissatisfied, 21.8% are satisfied and rest of them are highly dissatisfied
- **Only the savings bank account holder is eligible to get debit card/credit card :** It is interpreted from the above table – 4.14 have a 22.8% of respondent are highly

satisfied in only the savings bank account holder is eligible to get debit card/credit card. And 11.8% are neutral, 23.2% are dissatisfied, 27.4% are satisfied and rest of them are highly dissatisfied

- **Maximum amount that can be availed out of credit card is fixed by the bank based on the net worth of the customer :** It is interpreted from the above table – 4.14 have a 21.6% of respondent are highly satisfied in Maximum amount that can be availed out of credit card is fixed by the bank based on the net worth of the customer. And 23.4% are neutral, 14.6% are dissatisfied, 30.6% are satisfied and rest of them are highly dissatisfied
- **Nomination facility provided to the account holder :** It is interpreted from the above table – 4.14 have a 19.2% of respondent are highly satisfied in Nomination facility provided to the account holder. And 20.6% are neutral, 25.4% are dissatisfied, 27.8% are satisfied and rest of them are highly dissatisfied.

V. CONCLUSION

Most of the respondents are young and educated people who are availing the service of Karur Vysya bank in the study area. These respondents accept more quality of services from their bank. The service quality and satisfaction of the customers are influenced by the factors such as various banks branches, Maximum limit, procedure for depositing money by using ATM and Number of ATM center provided.

VI. REFERENCES

- [1] Mariyam Nashrath, Thitinut Akkadechanunt and Ratanawadee Chontawan(2011) “Nursing service quality”, volume 13, issue 4, December 2011, pages: 495–501
- [2] Wan-i lee, Yen Ting Chiu, Chia-Chi Liu and Chen-Yuan Chen (2011) “Assessing the effects of consumer involvement and service quality in a self-service setting”, volume 21, issue 5, September/October 2011, pages: 504–515
- [3] Tigineh Mersha, Ven Sriram, Haile Yeshanew and Yonatan Gebre (2012) “Perceived service quality in Ethiopian retail banks”, volume 54, issue 4, July/August 2012, pages: 551–565
- [4] David a. Collier (1991) “Decision sciences”, volume 22, issue 2, March 1991, pages: 406–420
- [5] Boris Snoj (1994) “Systems research”, volume 11, issue 1, January 1994, pages: 155–165
- [6] Allen klose and Todd finkle (1995) “Psychology & Marketing”, volume 12, issue 7, October 1995, pages: 637–646

To Cite This Article

Rajam, Sakthivel, R. (2016): “Customers Satisfaction Level Of Karur Vysya Bank In Coimbatore District” International Journal of Informative & Futuristic Research (ISSN: 2347-1697), Vol. 4 No. (4), December 2016, pp. 5854-5859, Paper ID: IJIFR/V4/E4/025.

MATERIAL AND METHOD OF GLASS FIBER REINFORCED POLYMER (GFRP) COMPOSITE STRENGTHENING FOR RC BEAM

Paper ID	IJIFR/V4/ E4/ 027	Page No.	5860-5874	Subject Area	Civil Engineering
Index Terms	RC Beam Material, Fiber Reinforced Polymer (FRP), Types Of Matrix Materials, Casting Of Beam, Strengthening Of Beams, Experimental Setup, Fabrication Of GFRP Plate.				

Prem Lata	Assistant Prof essor Department Of Civil Engineering Rajkiya Engineering College, Ambedkar Nagar (Uttar Pradesh), India
------------------	--

Abstract

worldwide, a great deal of research is currently being conducted concerning the use of fibre reinforced plastic wraps, laminates and sheets in the repair and strengthening of reinforced concrete member. FRP application is very effective way to repair and strengthen structures that have become structurally weak over their life span. FRP repair system provides an economically viable alternative to traditional repair system and materials. Experimental investigation on the flexural and shear behaviour of RC beams strengthened using continuous glass fibre reinforced polymer (GFRP) sheets are carried out.

I. INTRODUCTION

The maintenance, Rehabilitation and upgrading of structural members, is perhaps one of the most crucial problem in civil engineering applications. Additional strength may be needed to allow for higher loads to be placed on the structure. Strengthening may be needed to allow the structure to resist loads that were not anticipated in the original design. Strengthening system can improve the resistance of the existing structure to internal force in either a passive or active manner.

The selection of most suitable method for strengthening requires careful consideration of many factors including the following engineering issues:

- Magnitude of strength increase,
- Effect of changes in relative member stiffness,
- Size of project(Method involving special materials and method may be less cost-

effective on small projects)

- Environmental conditions
- In-place concrete strength and substrate integrity
- Dimensional/Clearance constraints
- Accessibility.
- Operation constraints
- Availability of materials, Equipment and qualified contractors
- Construction cost, maintenance costs and life-cycle costs
- Load testing to verify existing capacity or evaluate new techniques and materials.

i.) CONCRETE

Concrete is a construction material composed of Portland cement and water combined with sand, gravel, and crushed stone or other material such as expanded slag or vermiculite. Most structural work the concrete is designed to give compressive strength of 15 to 35 MPa. A concrete with trap rock may have a density of 2,483 Kg/m³. Concrete is stronger in compression than in tension, and steel bar called rebar or mesh is embedded in structural member to increase the tensile flexural strength. The fine aggregate used in this investigation was clean river sand, passing through 4.75 mm sieve with specific gravity of 2.68. The grading zone III as per Indian standard specification. The maximum size of coarse aggregate was 20 mm with specific gravity of 2.73.

For concrete, the maximum aggregate size used was 20 mm. nominal concrete mix of 1:1.5:3 by weight is used to achieve the strength of 20 N/ mm². The water cement ratio 0.5 used. Three cube specimens were cast and tested at the time of beam test (at the age 28 days) to determine the compressive strength of concrete. The average compressive strength of the concrete was 31 N/ mm².

ii.) CEMENT

Cement is a material, generally in powder form, that can be made into a paste usually by the addition of water, when molded or poured will set into a solid mass. The most widely used of the construction cement is Portland cement. It is a bluish- gray powder obtained by finely grinding the clinker made by strongly heating an intimate mixture of calcareous and argillaceous minerals. The chief raw material is mixture of high- calcium limestone, known as cement rock, and clay or shale. Blast – furnace slag may also be used in some cement and the cement is called Portland slag cement (PSC). The specific gravity is at least 3.10. Portland slag cement

iii.) FINE AGGREGATE

Fine aggregate / sand is an accumulation of grain of mineral matter derived from the disintegration of rocks. Usually commercial sand is obtained from river beds or from sand dunes originally formed. The most useful commercially are silica, sands, often above 98% pure. The weight varies from 1,538 to 1,842 Kg/m³, depending on the composition and size of grain. The fine aggregate was passing through 4.75 mm sieve and had a specific gravity of 2.68. The grading zone of fine aggregate was zone III as per Indian standard specifications.

iv.) COARSE AGGREGATE

Coarse aggregate are the crushed stone is used for making concrete. the commercial stone is quarried, crushed and graded. Much of the crushed stone used is granite, limestone and trap rock. The sizes are from 0.25 to 2.5 in (0.64 to 6.35cm), although larger size may be used for massive concrete aggregate. The maximum size of coarse aggregate was 20 mm and specific gravity of 2.78. the colors are usually reddish, greenish, or gray. The density is 2,723 Kg/m³, the specific gravity 2.72 and the crushing strength 158 to 220 MPa.

v.) WATER

Water fit for drinking is generally considered fit for making concrete. Water should be free from acids, oils, alkalizes, vegetables or other organic impurities. Soft water also poured weaker concrete. Water has two functions in a concrete mix. Firstly, it reacts chemically with the cement to form a cement paste in which the inert aggregates are held in suspension until the cement paste has hardened. Secondly, it serves as a vehicle or individual in the mixture of fine aggregate and cement.

vi.) REINFORCEMENT

The longitudinal reinforcement used were high- yield strength deformed bars of 12 mm diameter. The stirrups were made from mild steel bars with 6 mm diameter. The yield strength of steel reinforcements used in this experimental program was determined by performing the standard tensile test on the three specimens of each bar. The average proof stress at 0.2% strain of 12mm Φ bars was 437 N/mm² and that of 6 mm Φ bars was 240 N/mm².

II. FIBER REINFORCED POLYMER (FRP)

Fiber reinforced polymer (FRP) is a composite material made by combining two or more materials to give a new combination of properties. The mechanical and physical properties of FRP are controlled by its constituent properties and by structural configurations at micro level. FRP composite is a two phases material, hence its anisotropic properties. It is composed of fiber and matrix, which are bonded at interface.



Figure 1: Formation of fiber reinforced polymer composite

FIBER

A fiber is a material made into a long filament with a diameter generally in the order of 10 μ m. The aspect ratio of length and diameter can be ranging from thousand to infinity in

continuous fiber. The main function of the fiber is to carry the load and provide stiffness, strength, thermal stability and other structural properties in the FRP.

To perform these desirable functions, The fiber in FRP composite must have:

- i.) high modulus of elasticity for use as reinforced
- ii.) high ultimate strength
- iii.) low variation of strength among fiber
- iv.) high stability of their strength during handling
- v.) high uniformity of diameter and surface dimension among fiber.

Types of fiber used in fiber reinforced polymer composites

Glass fiber, Carbon fiber & Aramid fiber

Table 1: Properties Of Different Fiber

Material	Density (g/cm ³)	Tensile Modulus (E) (GPa)	Tensile Strength (σ) (GPa)	Specific Modulus (E/ρ) (E/s)	Specific Strength	Relative Cost
E-glass	2.54	70	3.45	27	1.35	Low
S-glass	2.50	86	4.90	34.5	1.8	Moderate
Graphite, high modulus	1.9	400	1.8	200	0.9	High
Graphite, high strength	1.7	240	2.6	140	1.5	High
Boron	2.6	400	3.5	153	1.3	High
Kevlar 29	1.45	80	2.8	55.5	1.9	Moderate
Kevlar 49	1.45	130	2.8	89.5	1.9	Moderate

i.) GLASS FIBERS

Their peculiar characteristic is their high strength. Glass is mainly made of silicon (SiO₂) with a tetrahedral structural (SiO₄). Some aluminum oxides and other metallic ions are then added in various proportion to either ease the working operations or modify some properties (e.g, S-glass fiber exhibit a higher tensile strength than E- glass)

Table 2: Typical composition of fiber glass (% in weight)

	E-glass	S-glass
Silicon oxide	54.3	64.20
Aluminium oxide	15.2	24.80
Iron oxide	-	0.21
Calcium oxide	17.2	0.01
Magnesium oxide	4.7	10.27
Sodium oxide	0.6	0.27
Boron oxide	8.0	0.01
Barium oxide	-	0.20
Various	-	0.03

ii.) CARBON FIBER

Carbon fiber consists of small crystallite of turbostratic graphite. These resemble graphite single crystals except that the layer planes are not packed in a regular fashion along the c-

axis direction. The single crystals are highly anisotropic with the plane module of the order of 100 GPa whereas the molecules perpendicular to the basal plane are only about 75 GPa. they have lower thermal expansion coefficients than both the glass and aramid fibers. The carbon fiber is an anisotropic material, and its transverse modulus is an order of magnitude less than its longitudinal modulus. As a result of this phenomenon, carbon composite laminates are more effective with adhesive bonding that eliminates mechanical fasteners.

Table 3: Typical Properties of Carbon Fibre

Typical Properties	Density (g/cm ³)	young modulus (GPa)	Tensile strength (GPa)	Tensile Elongation (%)
High Strength	1.8	230	2.48	1.1
High Modulus	1.9	370	1.79	0.5
Ultra – High Modulus	2.0-2. 1	520-620	1.03-1.31	0.2

iii.) ARAMID FIBER

It is also very heat resistant and decomposes above 400° C without melting. It was inveted by Stephanie kwolek of dupont from research into high performance polymer, and patented by her in 1966 and first marketed in 1971. Aramid or kelvar molecules have polar group accessible for hydrogen bonding. Water that enters the interior of the fiber can take place of bonding between molecules and reduce the materials strength, while the available groups at the surface lead to good wetting properties. This is important for bonding the fiber to other types of polymer, forming a fiber reinforced plastic. This same property also makes the fiber feel more natural and “sticky” compared to non- polar polymer like polyethylene. In structural application, kelvar fiber can be bonded to one another or to other material to form a composite. Kelvar main weaknesses are that it decomposes under alkaline conditions or when exposed to chlorine. While have a great tensile strength, sometimes in excess of 4.0 GPa, like all fiber it tends to bickle in compression.

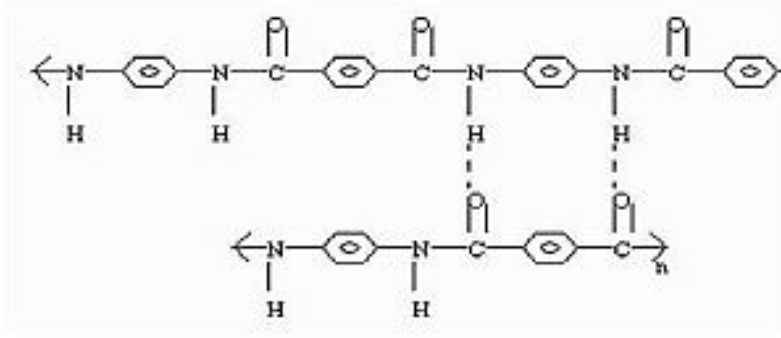

Figure 3: Structure Of Aramid Fiber

III. TYPES OF MATRIX MATERIAL

Fibers, since they cannot transmit loads from one to another, have limited use in engineering application. When they are embedded in a matrix material, to form a composite, the matrix serves to bind the fiber together, transfer loads to the fiber, and damage due to handling. The matrix has a strong influence on several mechanical properties of the composite such as

transverse modulus and strength, shear properties, and properties in compression. Physical and chemical characteristics of the matrix such as melting or curing temperature, viscosity, and reactivity with fiber influence the choice of fabrication process.

Commonly used matrix materials are-

i. Epoxy Resin

Epoxy resins are relatively low molecular weight pre- polymers capable of being processed under a variety of conditions. Two important advantages of these resins are over unsaturated polyester resins are: first, they can partially cured and stored in that state, and second they exhibit low shrinkage during cure. Epoxy resins are characterized by the presence of a three- member ring containing two carbons and an oxygen (epoxy group or epoxide or oxirane ring). Epoxy is the first liquid reaction product of bisphenol- A with excess of epichlorohidrin and this resins is known as diglycidylether of bisphenol A (DGEBA).

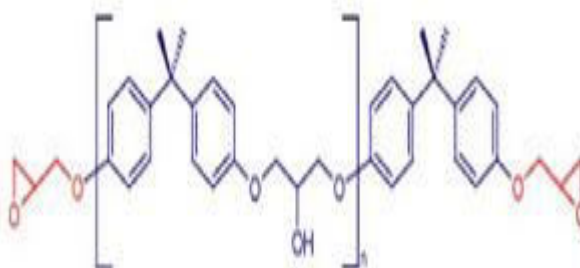

Figure 2: Structure of DGEBA

The primary and secondary amines are reactive curing agents. the primary amino group is more reactive towards epoxy than secondary amino group are consumed(95%), whereas only 28% of secondary amino group are consumed.

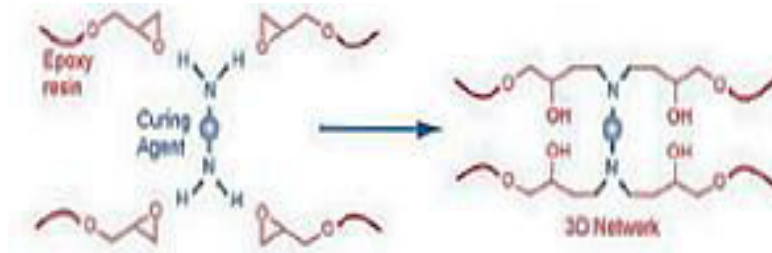

Figure 3: The curing of epoxy resin with primary amines

The composite materials constitute 3-9% of total structural weight of the commercial aircrafts such as Boeing 767 or Boeing 777. Composite and laminate industry uses 28% of epoxy resins produced.

Table 3: Properties of epoxy resin

Property	
Density, g/cm ³	1.2-1.3
Tensile modulus, MPa	55-130
Tensile modulus, GPa	2.75-4.10
Thermal expansion, 10 ⁻⁶ /°C	45-65
Water absorption, % in 24h	0.08-0.15

The resin and hardener are used in this study is araldite LY 556 and hardener HY 951, respectively. Araldite LY_ 556, an unmodified epoxy resin based on bisphenol- A and the hardener (ciba- geig, india) HY 951 (8% of total epoxy taken) an aliphatic primary amine, were mixed properly.

Table 4: Properties of epoxy resin and hardener

Properties	Araldite LY556	Hardener HY951
Color	clear	Colorless
Odor	Slight	Ammonia
Physical	liquid	Liquid
Solubility in water	insoluble	Miscible
Vapor pressure	<0.01Pa at 20°C	<0.01 mmHg at 20°C
Specific gravity	1.15-1.2 at 25°C	1 at 20°C
Boiling point	>200°C	>200°C
Decomposition Temperature	>200°C	>200°C

ii. Unsaturated Polyester Resins

Unsaturated Polyesters are long- chain linear polymer containing a number of carbon double bonds. They are made by a condensation reaction between a glycol (ethylene, propylene, diethylene glycol) and an unsaturated dibasic acid. A typical polyester resin made from reaction of maleic acid and diethylene glycol is shown below:

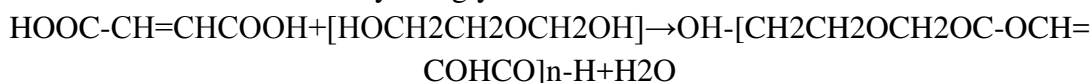

The length of the molecule or degree of polymerization n may vary. The resin will generally be a solid but is dissolved in a monomer such as styrene. The solution viscosity can be controlled by the percent styrene and is generally quite fluid.

Table 5: Typical Properties Of Cast Thermosetting Polyesters

Property	
Density, g/cm ³	1.1-1.4
Tensile strength, MPa	24.5103.5
Tensile modulus, GPa	2-4.4
Thermal expansion, 10 ⁻⁶ /°C	55-100
Water absorption, % in 24h	0.15-0.6

iii. Adhesives

The implementation of FRP- based structural strengthening requires the use of adhesives. the choice of the most suitable adhesives as well as the type of surface treatment to be carried out prior to FRP application shall be made on the basis of available substrate and properties of the selected FRP system. Technical data sheet for FRP materials usually report the indication of the adhesive to be used as a function of the structure to be strengthened.

An adhesive is a material quite often of a polymeric nature capable of creating a link between at least two surface and able to share loads. There are many types of natural and synthetic adhesives (elastomers, thermoplastic, and mono- or bi-component thermosetting resins) the most suitable adhesive for composite materials are based on epoxy resins.

iv. Casting Of Beams

Two set of beams were casted for this experimental test program. In SET I three beams (F1,F2 and F3) weak in flexural were casted using same grade of concrete and reinforcement detailing. In SET II three beams (S1,S2 and S3) weak in shear were casted using same grade of concrete and reinforcement detailing. The dimensions of all the specimen are identical. The cross sectional dimensions of the both the set of beams is 250 mm by 200 mm and length is 2300 mm. in SET I beams 2, 12 mm ϕ bars are provided as the main longitudinal reinforcement and 6 mm ϕ bars as stirrups at a spacing of 75 mm C/C where as in SET II beams beam 3, 12 mm ϕ bars are provided as the main longitudinal reinforcement and without any stirrups.

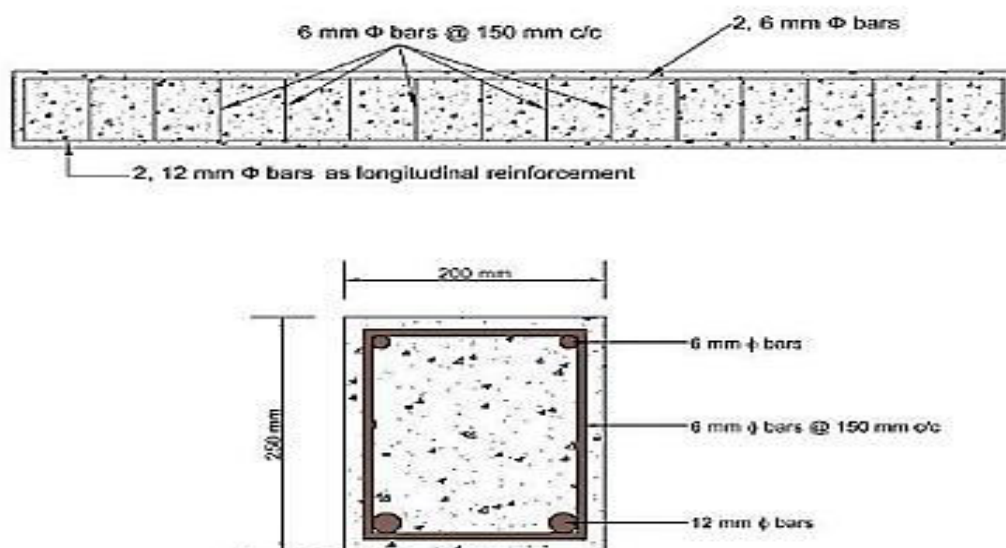

Figure 4: Section of set I beams

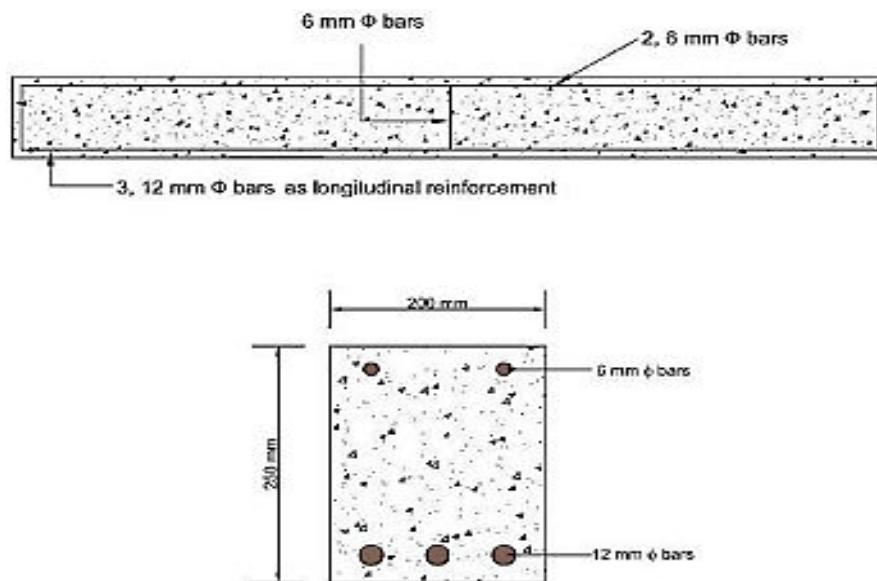

Figure 5: Section of SET II beams

►► **Material for Casting**

- i.) Cement- Portland cement (PSC)- 43 grade (kornak cement) was used for the investigation.
- ii.) Fine aggregate- the fine aggregate passing through 4.75 mm sieve and had a specific gravity of 2.68.
- iii.) Coarse aggregate- the coarse aggregate used were of two grades, non- reactive and available in local quarry. One grade contains aggregates passing through 10mm and retained on 4.75mm sieve. Another grade contained aggregates passing through 20mm sieve but retained on 20 mm sieve.
- iv.) Water- Ordinary tap water for concrete mix in all mix
- v.) Reinforcing steel- HYSD bars of 12 mm dia were used as main reinforcement. 6 mm dia mild steel bars were used for shear reinforcement.

►► **Form Work**

It should be strong enough to take the dead load and live load, during construction and also it must be rigid enough so that any building, twisting or sagging due to the load is minimized, wooden beams, mild steel sheet, wood and any several other materials can also be used. The form work used for casting of the entire specimen consists of mould prepared with two channel section of iron bolted by iron plates at the ends. The form work was thoroughly cleaned and all the corners and junctions were properly sealed by plaster of Paris to avoid leakage of concrete through small openings. Shuttering oil was then applied to the form work carefully keeping in view a clear cover of 20mm for the top and bottom bars.

►► **Mixing of Concrete**

Mixing of concrete should be done thoroughly to ensure that concrete of uniform quantity is obtained. Hand mixing is done in small work, while machine mixing is done for all big and important work. Turn the dry materials at least three times until the colour of the mixture is uniform. Add water slowly while you turn the mixture again at least three times, or until you

obtain the proper consistency. Usually 10% extra cement is added in case of hand mixing to account for inadequacy in mixing.

▶▶ **Compaction**

All specimens were compacted by using needle vibrator for good compaction of concrete. Sufficient care was taken to avoid displacement of the reinforcement cage inside the form work. Finally the surface of the concrete was levelled and finished and smoothed by metal trowel and wooden float.

▶▶ **Curing of Concrete**

The concrete is cured to prevent or replenish the loss of the water which is essential for the process of hydration and hence for hardening. Also curing prevent the exposure of concrete to a hot atmosphere and to drying winds which may lead to quick drying out of moisture in the concrete and thereby subject it to contraction stress at a stage when the concrete would not be strong enough to resist them. Concrete is usually cured by water although scaling compounds are also used.

v. **STRENGTHENING OF BEAMS**

Before bonding the composite fabric onto the concrete surface, the required region of concrete surface was made rough using a coarse sand paper texture and cleaned with an air blower to remove all dirt and debris. Once the surface was prepared required standard, the epoxy resin was mixed in accordance with manufacturer's instructions. Mixing was carried out in a plastic container and was continued until the mixture was in uniform colour. When this was completed and the fabrics had been cut to size, the epoxy was applied to the concrete surface. The composite fabrics were then placed on top of epoxy resin coating and the resin was squeezed through the roving of the fabric with the roller. Air bubbles entrapped at the epoxy/ concrete or epoxy/ fabric interface were to be eliminated. Then the second layer of the epoxy resin was squeezed through the roving of the fabric with the roller and the above process was repeated. During hardening of the epoxy, a constant uniform pressure was applied on the composite fabrics surface in order to extrude excess epoxy resin and to ensure good contact between the epoxy, the concrete and the fabric. This operation is carried out at room temperature. Concrete beams strengthened with glass fibre fabrics were cured for 24 hours at room temperature before testing.



Figure 6: Application of epoxy and hardener on the beam



Figure 7: Fixing of GFRP sheet on the beam



Figure 8: Roller used for removal of air bubbles

IV. EXPERIMENTAL SETUP

After the curing period of 28 days was over, the beam as washed and its surface was cleaned for clear visibility of cracks. The most commonly used load arrangement for testing of beams will consist of two-point loading. This has advantage of a substantial region of nearly uniform moment coupled with very small shears, enabling the bending capacity of the central portion to be assessed. If the shear capacity of the member is to be assessed, the load will normally be concentrated at a suitable shorter distance from a support.

The specimen was placed over the two steel rollers bearing leaving 150 mm from the ends of the beam. The remaining 2000mm was divided into three equal parts of 667 mm as shown in fig. Two point loading arrangement was done. Loading was done by hydraulic jack of capacity 100 KN. Three number of dial gauges were used for recording the deflection of the beams. One dial gauge was placed just below the centre of the beam and the remaining two dial gauges were placed just below the point loads to measure deflections.

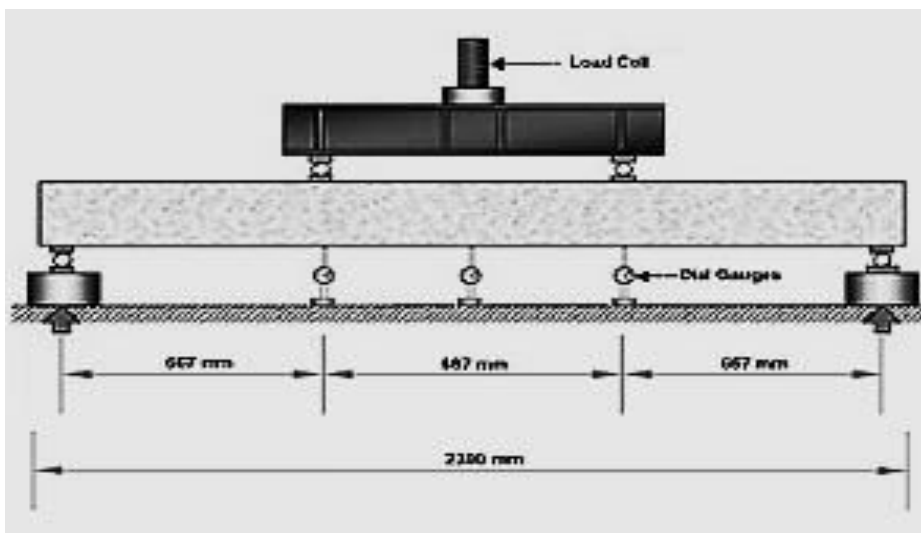

Figure 9 : Two Point Loading Experiment Setup

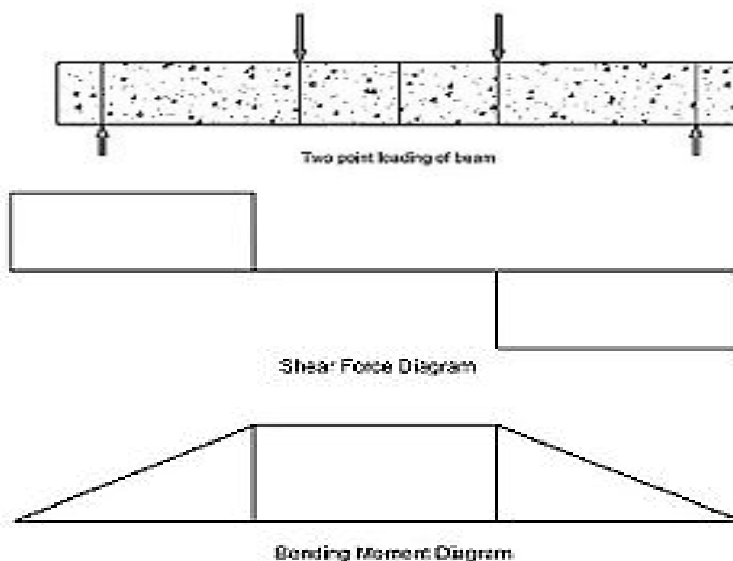

Figure 10: Shear Force And Bending Moment Diagram For Two Point Loading

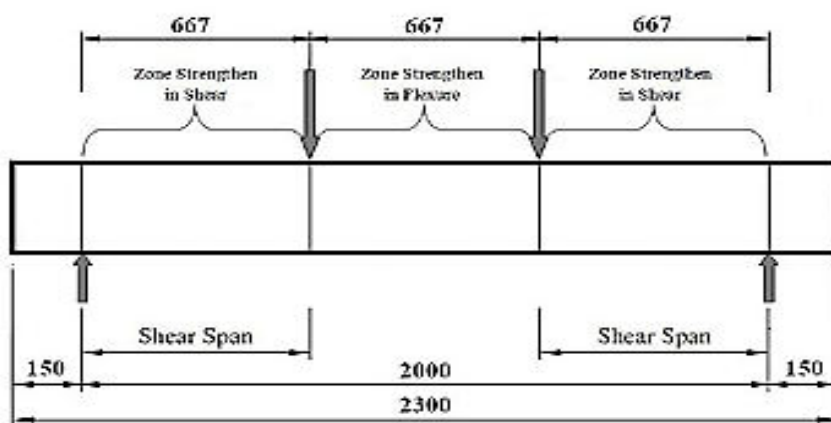

Figure 10: Shear strengthening zone and flexure strengthening zone beam



Figure 11: Experimental Setup For Testing Of Beams

V. FABRICATION OF GFRP PLATE

The industry has evolved over a dozen separate manufacturing processes as well as a number of hybrid processes. Each of these processes offers advantages and specific benefits which may apply to the fabrication of composites. Hand lay-up and spray-up are two basic moulding processes. The hand lay-up process is the oldest, simplest, and most labour intense fabrication method. In hand lay-up method liquid resin is placed along with reinforcement (woven glass fibre) against finished surface of an open mould. Chemical reaction in the resin hardens the material to a strong, light weight product. The resin serves as the matrix for the reinforcing glass fibres, much as concrete acts as the matrix for steel reinforcing rods. The percentage of fibre and matrix was 50:50 in weight. The following constituent materials were used for fabricating the plate:

- 1- E-glass woven roving as reinforcement
- 2- Epoxy as resin
- 3- Hardener as demine (catalyst)
- 4- Polyvinyl alcohol as a releasing agent

Contact moulding in an open mould by hand lay-up was used to combine piles of woven roving in the prescribed sequence. Flat plywood rigid platform was selected. A plastic sheet was kept on the plywood platform and a thin film of polyvinyl alcohol was applied as a releasing agent by use of spray gun. Laminating stars with the application of a gel coat (epoxy and hardener) deposited on the mould by brush, whose main purpose was to provide a smooth external surface and to protect the fibres from direct exposure to the environment. Ply was cut from roll of woven roving. Layers of reinforcement were placed on the mould at top of the gel coat and gel coat was applied again by brush. Any air which may be entrapped was removed using serrated steel rollers. The process of hand lay-up was the continuation of the above process before the gel coat had fully hardened. Again, a plastic sheet was covered the top of plate by applying polyvinyl alcohol inside the sheet as releasing agent. Then, a heavy flat metal rigid platform was kept top of the plate for compressing purpose. The plates were left for a minimum of 48 hours before being transported and cut to exact shape for testing.

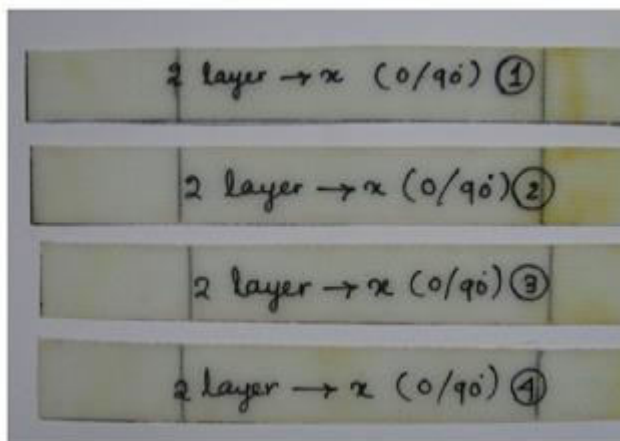

Figure 12: Specimen for tensile testing in INSTRON 1195



Figure 13: Experimental setup of INSTRON 1195

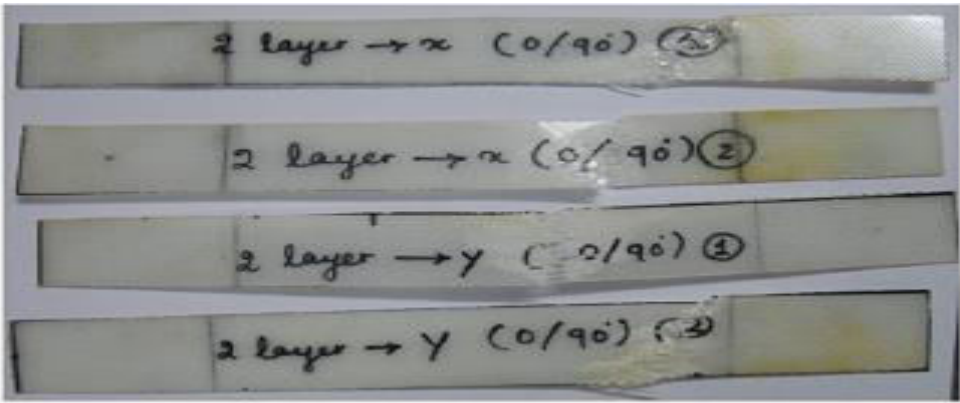

Figure 14: Specimen Failure After Tensile Test

VI. RESULT

The ultimate stress, ultimate load and young’s modulus are determined experimentally by performing unidirectional tensile tests on specimens cut in longitudinal and transverse direction, and at 45° to the longitudinal direction, as described in ASTM standard: D638-08 and D 3039/D3039M- 2006. A constant rectangular cross section was prepared in all cases. The dimension of the specimen was taken as below:

Table 6: Size of the specimen for tensile test

Length(mm)	Width(mm)	Thickness(mm)
200	24	0.6

The specimen were cut from the plates themselves by diamond cutter or by hex saw after cutting in the hex saw, it was polished in the polishing machine. At least three replicate sample specimens were tested and mean values adopted. Coupons were machined carefully to minimize any residual stresses after they were cut from the plate and the minor variations in dimensions of different specimens are carefully measured. For measuring the young’s modulus, the specimen is loaded in INSTRON 1195 universal testing machine monotonically to failure with a recommended rate of extension (rate of loading) of 5 mm/minute. Specimen were fixed in the upper jaw first and then gripped in the movable jaw (lower jaw). Gripping of the specimen should be as much as possible to prevent the slippage. Here, it was taken as 50mm in each side. Initially strain was kept at zero. The load, as well as the extension, was recorded digitally with the help of a load cell and an extensometer respectively. From these data, engineering stress vs. Strain curve was plotted, The initial slope of which gives the young’s modulus. The ultimate stress and ultimate load were obtained at the failure of the specimen.

Table 7: Ultimate Stress, Ultimate Load and Young’s Modulus of GFRP plate

	Ultimate stress (MPa)	Ultimate load (KN)	Young’ modulus (MPa)
GFRP plate of 2- layers	334.5	4.817	11310

VII. CONCLUSIONS

In this experiment investigation on the flexural and shear behaviour of reinforced concrete beams strengthened by GFRP sheets are studied. Initial flexural cracks at a higher load by strengthening the beam at soffit. The ultimate load carrying capacities of the strengthening beams are 33% more than the controlled. The material and processes is applying very carefully. The material and process is shown in fig and based on experimental setup.

VIII. REFERENCES

- [1] A. Shahawy, M. arockiasamy, T. Beitelman, R. sowrirajan “ reinforced concrete rectangular beams strengthened with GFRP laminates “ composites: part B 27 B(1996) 225-233
- [2] Victor N. Kaliakin, Michael J. Chajes and Ted F. “Analysis of concrete beams reinforced with externally bonded woven composites fabrics” composites: part B 27B (1996) 235-244
- [3] Ahmed Khalifa, William J. Gold, Antonio Nanni, and Abdel Aziz M.I. “journal of composites for construction vol2, No. 4, November, 1998. 195-202
- [4] B. Taljsten and L. Elfgren “ strengthening concrete beams for shear using GFRP- materials” evaluation of different application methods” composites: Part B31 (2000) 87-96
- [5] Thanasis C. Triantafillou and Costas P. Antonopoulos “Design flexural member strengthened in shear with FRP” Journal of composites for Construction, VOL. 4, November, 2000. 198-205

To Cite This Article

Lata, P. (2016): “Material And Method Of Glass Fiber Reinforced Polymer (GFRP) Composite Strengthening For RC Beam” *International Journal of Informative & Futuristic Research (ISSN: 2347-1697)*, Vol. 4 No. (4), December 2016, pp. 5860-5874, Paper ID: IJIFR/V4/E4/027.

REVIEW ON SMART CRAWLER FOR EFFICIENTLY HARVESTING DEEP-WEB INTERFACES

Paper ID	IJIFR/V4/ E4/ 028	Page No.	5875-5880	Subject Area	Computer Engineering
Index Terms	Basic Crawler, Deep Web, Adaptive Learning, Form Classifier, Ranker, Feature Selection				

1 st	Pallavi Pingale	Student, Department Of Computer Engineering Central India Institute of Technology, Indore
2 nd	Dr. Dhanraj Verma	Principal, Central India Institute of Technology, Indore

Abstract

In today's era, Web has been rapidly deepened by myriad searchable databases online, where data are hidden behind query interfaces. There has been increased interest in techniques that help efficiently locate deep-web interfaces. However, due to the large volume of web resources and the dynamic nature of deep web, achieving wide coverage and high efficiency is a challenging issue. The review paper contains survey on the basic crawler and the smart crawlers. The two-stage framework, namely SmartCrawler, for effectively harvesting deep web interfaces. In the first stage that is site locating, center pages are searched with the help of search engines which in turn avoid visiting a large number of pages. To achieve more precise results for a focused crawl, SmartCrawler ranks websites to prioritize highly relevant ones for a given topic. In the second stage, adaptive link-ranking achieves fast in-site searching by excavating most relevant links. To eliminate bias on visiting some highly related links in hidden web directories, design a link tree data structure to acquire wider coverage for a website. The experimental result on a set of representative domains show the agility and accuracy of proposed crawler framework which efficiently retrieves deep web interfaces from large-scale sites and obtains higher harvest rates than other crawlers.

I. INTRODUCTION

In the recent years, the Web has been rapidly deepened with the prevalence of databases online. A web crawler is a system for the bulk downloading of web pages. Web crawlers are used for a variety of purposes. Most prominently, they are one of the main components of web search engines, systems that assemble a corpus of web pages, index them, and allow users to issue queries against the index and find the web pages that match the queries. A related use is web archiving, where large sets of web pages are periodically collected and archived for posterity. A third use is web data mining, where web pages are analyzed for statistical properties, or where data analytics is performed on them. Finally, web monitoring services allow their clients to submit standing queries, or triggers, and they continuously crawl the web and notify clients of pages that match those queries.

The crawler consists of multiple processes running on different machines connected by a high-speed network. Each crawling process consists of multiple worker threads, and each worker thread performs repeated work cycles. At the beginning of each work cycle, a worker obtains a URL from the Frontier data structure, which dispenses URLs according to their priority and to politeness policies. The worker thread then invokes the HTTP fetcher. The fetcher first calls a DNS sub-module to resolve the host component of the URL into the IP address of the corresponding web server, and then connects to the web server, checks for any robots exclusion rules, and attempts to download the web page.

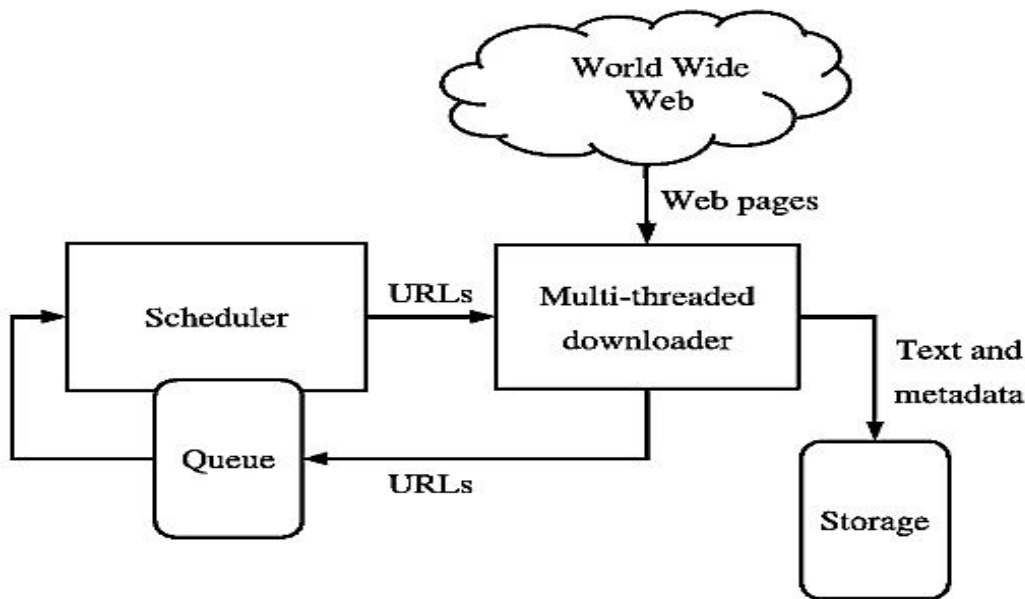

Figure 1: Basic Crawler

Web crawlers download web pages by starting from one or more seed URLs, downloading each of the associated pages, extracting the hyperlink URLs contained therein, and recursively downloading those pages. Therefore, any web crawler needs to keep track both of the URLs that are to be downloaded, as well as those that have already been downloaded (to avoid unintentionally downloading the same page repeatedly). The required state is a set of URLs, each associated with a flag indicating whether the page has been

downloaded. The operations that must be supported are: Adding a new URL, retrieving a URL, marking a URL as downloaded, and testing whether the set contains a URL. There are many alternative in-memory data structures that support these operations. However, such an implementation does not scale to web corpus sizes that exceed the amount of memory available on a single machine. To scale beyond this limitation, one could either maintain the data structure on disk, or use an off-the-shelf database management system. Either solution allows maintaining set sizes that exceed main memory; however, the cost of accessing items in the set (particularly for the purpose of set membership test) typically involves a disk seek, making it a fairly expensive operation. To achieve high performance, a more specialized approach is needed.

II. SURVEY REVIEW

1. Kevin Chen-Chuan Chang observes that, across subsystems, the system integration of an integration system is itself non-trivial— which presents both challenges and opportunities beyond subsystems in isolation. On the other hand, he also observe that, across subsystems, there emerge unified in-sights of “holistic integration”— which leverage large scale itself as a unique opportunity for information integration.
2. Mike Burner designed the Internet Archive Crawler was the first paper that focused on the challenges caused by the scale of web. It uses multiple machines to crawl the web and it crawled on 100 million URLs. Each crawler process reads a list of seed URLs for its assigned sites from disk into per-site queue, and then it uses asynchronous I/O instructions to fetch pages from these queues in parallel. It has also deal with the problem of changing DNS records, so it keeps the historical archive of hostname to IP mapping.
3. Heydon and Najork present’s a web crawler which was highly scalable and easily extensible. It was written in Java. The first version was non-distributed and later the distributed version was made available which split up the URL space over the crawlers according to host name and avoid the potential bottleneck of a centralized URL server.
4. Yan et al. describe’s URLbot, which is single process web crawler. It is able to scale to extremely large web collection without performance degradation. It crawls over two month and downloads the 6.4 billion web pages. In addition, the authors address the issue of crawler traps and propose ways to ameliorate the impact of such sites on the crawling process.
5. Brin and Page’s 1998 paper outlining the architecture of the first-generation Google system contains a short description of their crawler. The original Google crawling system consisted of a single URLserver process that maintained the state of the crawl, and around four crawling processes that downloaded pages. Both URLserver and crawlers were implemented in Python.
6. Shkapenyuk and Suel’s Polybot web crawler represents another “blueprint design.” Polybot is a distributed system, consisting of acrawl manager process, multiple

downloader processes, and a DNS resolver process. The paper describes scalable data structures for the URL frontier and the “seen-URL” set used to avoid crawling the same URL multiple times; it also discusses techniques for ensuring politeness without slowing down the crawl. Polybot was able to download 120 million pages over 18 days using four machines.

III. TWO-STAGE ARCHITECTURE

SmartCrawler is designed with a two-stage architecture, site locating and in-site exploring. The first site locating stage finds the most relevant site for a given topic, and then the second in-site exploring stage uncovers searchable forms from the site.

Generally, the site locating stage starts with the set of sites in database. Seeds sites are candidate sites given for SmartCrawler to start crawling, which begins by following URLs from chosen seed sites to explore other pages and other domains. When the number of unvisited URLs in the database is less than a threshold during the crawling process, SmartCrawler performs reverse searching of known deep web sites for center pages and feeds these pages back to the site database. Site Frontier fetches homepage URLs from the site databases, which are ranked by Site Ranker to prioritize highly relevant sites. The Site Ranker is improved during crawling by an Adaptive Site Learner, which adaptively learns from features of deep-web sites found. To achieve more accurate results for a focused crawl, Site Classifier categorizes URLs into relevant or irrelevant for a given topic according to the homepage content. The most relevant site is found in the first stage.

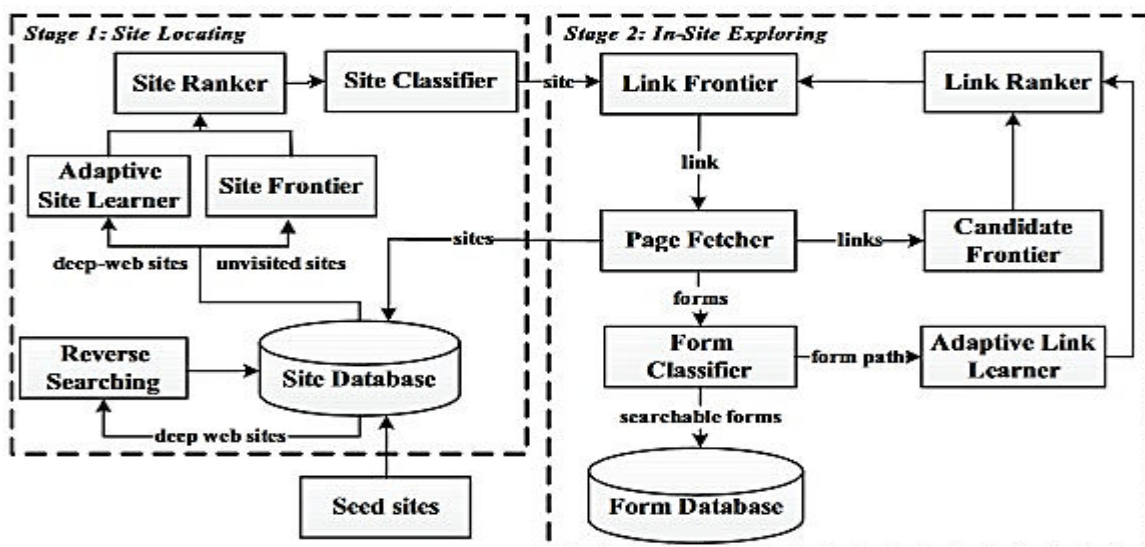

Figure 2: The two-stage architecture of SmartCrawler

The second stage performs efficient in-site exploration for excavating searchable forms. Links of a site are stored in Link Frontier and corresponding pages are fetched and embedded forms are classified by Form Classifier to find searchable forms. Additionally, the links in these pages are extracted into Candidate Frontier. To prioritize links in Candidate Frontier, SmartCrawler ranks them with Link Ranker. Note that site locating stage and in-site exploring stage are mutually intertwined. When the crawler discovers a new site, the site’s URL is inserted into the Site Database. The Link Ranker is adaptively

improved by an Adaptive Link Learner, which learns from the URL path leading to relevant forms.

IV. THE PROCESS OF SITE LOCATING

The site locating stage finds relevant sites for a given topic, consisting of site collecting, site ranking, and site classification.

1. **Site Collecting**-SmartCrawler strives to minimize the number of visited URLs, and at the same time maximizes the number of deep websites. To achieve these goals, using the links in downloaded webpages is not enough. This is because a website usually contains a small number of links to other sites, even for some large sites.
2. **Site Ranking**-In SmartCrawler, Site Ranker assigns a score for each unvisited site that corresponds to its relevance to the already discovered deep web sites.
3. **Site Classifier**-After ranking Site Classifier categorizes the site as topic relevant or irrelevant for a focused crawl, which is similar to page classifiers in FFC and ACHE.

V. CONCLUSION

In this review paper, finally all the survey is related to SmartCrawler which is a two-stage crawler for efficiently harvesting Deep-Web Interface. It has been shown that above approach achieves both wide scopes for deep web interfaces and maintains highly efficient crawling. SmartCrawler is a focused crawler consists of two stages: site locating and balanced in site exploring. SmartCrawler performs site -based locating by reversely searching the known deep web sites for centre pages, which can efficiently find many data sources for sparse domains. SmartCrawler achieves more accurate results by ranking collected sites and focusing the crawling on a given topic. The in -site exploring stage uses adaptive link-ranking to search within a site and design a link tree for eliminating bias toward certain directories of a website for wider coverage of web directories.

VI. REFERENCES

- [1] Feng Zhao, Jingyu Zhou, Chang Nie, Heqing Huang, Hai Jin, "SmartCrawler: A Two-stage Crawler for Efficiently Harvesting Deep-Web Interfaces", IEEE Transaction on services computing, Vol-99, 2015.
- [2] M. Burner, "Crawling towards Eternity: Building an Archive of the World Wide Web," Web Techniques Magazine, vol. 2, pp. 37-40, 1997.
- [3] Allan Heydon and Marc Najork, Mercator: A scalable, extensible webcrawler. World Wide Web Conference, 2(4):219-229, April 1999.
- [4] Jenny Edwards, Kevin S. McCurley, and John A. Tomlin. An adaptive model for optimizing performance of an incremental web crawler. In Proceedings of the Tenth Conference on World Wide Web, pages 106-113, Hong Kong, May 2001. Elsevier Science.
- [5] Luciano Barbosa and Juliana Freire. Searching for hidden-web databases. In WebDB, pages 1-6, 2005.
- [6] Soumen Chakrabarti, Martin Van den Berg, and Byron Dom. Focused crawling: a new approach to topic-specific web re-source discovery. Computer Networks, 31(11):1623-1640, 1999.

- [7] Jayant Madhavan, David Ko, Lucja Kot, Vignesh Ganapathy, Alex Rasmussen, and Alon Halevy. Google's deep web crawl. Proceedings of the VLDB Endowment, 1(2):1241–1252, 2008.
- [8] Olston Christopher and Najork Marc. Web crawling. Foundations and Trends in Information Retrieval, 4(3):175–246, 2010.
- [9] Balakrishnan Raju and Kambhampati Subbarao. Sourcerank:Relevance and trust assessment for deep web sources based on inter-source agreement. In Proceedings of the 20th international conference on World Wide Web, pages 227–236, 2011.
- [10] Denis Shestakov and Tapio Salakoski. On estimating the scale of national deep web. In Database and Expert Systems Applications, pages 780–789. Springer, 2007.
- [11] Shestakov Denis, On building a search interface discovery system. In Proceedings of the 2nd international conference on Resource discovery, pages 81–93, Lyon France, 2010. Springer.
- [12] Luciano Barbosa and Juliana Freire. An adaptive crawler for locating hidden-web entry points. In Proceedings of the 16th international conference on World Wide Web, pages 441–450. ACM, 2007.

To Cite This Article

Pingale,P., Verma, D. (2016): “Review On Smart Crawler For Efficiently Harvesting Deep-Web Interfaces” *International Journal of Informative & Futuristic Research (ISSN: 2347-1697)*, Vol. 4 No. (4), December 2016, pp. 5875-5880, Paper ID: IJIFR/V4/E4/028.

CHANGING ROLE OF THE FUTURE ACADEMIC LIBRARY PROFESSIONAL IN THE E-LEARNING ENVIRONMENT : CHALLENGES AND ISSUES

Paper ID	IJIFR/V4/ E4/ 031	Page No.	5881-5890	Research Area	E-Learning
Index Terms	Information Technology, Web Technology, Technology challenges, e-resources, e-learning environment				

Dr. G. S. Biradar

Assistant Librarian
Gulbarga University Post Graduate Centre
Raichur, Gulbarga - Karnataka , India

Abstract

As the information technologies are changing day-to-day and growing at a tremendous speed, the knowledge society is becoming more complex, competitive and dependent on technological changes and information explosion. The need for e-information services to the users are also growing and becoming very essential. The impact of web based e-learning and teaching environment has influenced every facet of library and information services in academic libraries and providing new opportunities and challenges to the library professional for involvement in the knowledge based society including electronic and multimedia publishing, Internet based-information services, global networking, web based digital resources etc. The future visions need for changes in academic libraries, trends and challenges before the library professional in the e-learning environment and the various changing roles of the academic library professional also have been discussed in this study.

I. INTRODUCTION

Librarians are charged with selecting and organizing resources and instructing patrons on how to locate and use these, and preserving information regardless of format or technology. The information revolution and the knowledge that is available on the Web have created new challenges to these traditional professional ethics. The emerging challenges of acquiring and providing access to electronic knowledge resources require librarians to change their role from traditional librarian to information scientist by learning and applying new skills to understand the evolving technologies to manage and provide quality on-line



information service to the knowledge society. So the vision of the future academic library professional must be to create a World Class Networked Global Library and Information Centre to provide timely web based quality information service to the user in time in the e-learning environment.

The information atmosphere around the world is changing every minute and growing at a tremendous speed due to the emergence of the web based Information and Communication Technologies (ICT), globalization of networks and Internet. Hence ensuring and organizing access to educational materials in the electronic environment is an important factor in determining realistic requests for development and advancement of education. The information revolution and the pervasive thinking that everything is available on the Web have created new challenges to the traditional library professional ethics. Acquiring and providing access to electronic knowledge resources require library professional to change their role from traditional librarian to information scientist by learning and applying new skills to understand the evolving technologies to manage and provide quality on-line information service to the patrons of the knowledge society. Since, almost all the educational institutions, organizations, universities and academic associations have created their own websites with the digital repositories on Internet, the global networked environment has paved the way and opportunity to e- literacy. The impact of web based e-learning and teaching environment has influenced very much on every facets of library and information services in Academic Libraries and providing new opportunities and challenges to the library professional.

II. OBJECTIVES OF THE PRESENT STUDY

The objectives of this study are given below:

- 1) The primary objective of this study is to analyze and explore the changing vision and the roles of future academic library professionals accordingly to meet the changes and challenges in the e- learning environment.
- 2) To document the various changes and challenges evolved before the academic library professional in the e- learning environment
- 3) To define and explain the concept of e-literacy and digital learning environment in academic institutions which changes the role of library professional to the real situation.
- 4) To discuss about the various skills needed for the library professional to meet the present online and digital needs of the user.

III. VISION OF THE FUTURE ACADEMIC LIBRARY PROFESSIONAL

Technology will continue to change, and libraries and librarians have to use the changing technology to provide the best access and service to their patrons. Electronic information creates challenges for the library community at its very foundation, moving it away from the traditional paper-and-print format to an ethereal world of circuits and connectivity. The library is no longer defined simply as a building or a physical repository that houses information. So the essential future vision of the academic library professional to achieve the necessary information- transformation and to face the digital information needs of the user should concentrate on the following:



- The vision of the future academic library professional must be to create a World Class Networked Global Library and Information Centre to provide web based quality information service to the user in time in the e-learning environment.
- The librarians must change the library environment as pathways to high quality information in a variety of electronic media and information sources.
- Library professional must assert their evolving roles in more pro-active ways, both in the context of their academic institutions and in the context of increasing competitive markets for information dissemination and retrieval.
- *The vision for the 21st Century librarians* must offer electronic teaching and learning both to guide and beckon the library profession as education leaders. They should shape the library programme and serve as a tool for library media specialists to use to shape the learning of students in the academic institutions.

IV. REVIEW OF LITERATURE ON CHALLENGING ROLES OF LIBRARIANS IN THE E-LEARNING ENVIRONMENT

- The concept of a digital library and its usages for faculty at the university and the changing role of librarians in creating and managing digital libraries are described by Joseph Janes, Assistant Professor at the University of Washington Information School. He also presented a case study of the Internet Public Library <<http://www.ipl.org/>> developed between 1994 and 1995 by the then School of Information and Library Studies at the University of Michigan which illustrated how a digital library can support education.
- Christine Dugdale in her presentation on Electronic Library System which offers access to electronic Bonk (2004), reviews the trends in online e-literacy programmes in colleges and universities both in the United States and around the world, which describe the desire of teachers to empower the learner, the power of future developments such as simulations and virtual world technology in education.
- Karen Jurasek says that libraries must uphold professional standards and a commitment to service. Also he describes that along with its services, resources, and technology, the library is both a physical and virtual space for the 21st century. He also concludes that the academic library professional must develop a virtual electronic learning system to enhance the user's knowledge and to accommodate an increasingly diverse group of users.
- Dewey likewise promotes the embedding of academic librarians into as many campus venues as possible as a way of "advancing colleges' and universities' strategic priorities through constant collaboration" and Gamble argues for the recognized presence of academic librarians on university governance committees, faculty unions, clubs and student activities as legitimate modes for providing university service that ought to be valued and rewarded by library administration.

V. E-LITERACY/VIRTUAL LEARNING ENVIRONMENTS IN ACADEMIC INSTITUTIONS AND THE DIGITAL FUTURE OF THE ACADEMIC





LIBRARIES

E-learning is a means of becoming literate, involving new mechanisms for communication, such as: computer networks, multimedia, content portals, search engines, electronic libraries, distance learning, and web-enabled classrooms. Different web based applications such as email, real-time conference; Web Cam, etc. are being used as important tools in the process of e-learning.

Technological innovations have brought tremendous changes in the whole education process and have led to a paradigm shift from teacher based education to a learner based education system. Developments in the electronic networking frontier have changed the whole dimension of the education system. This has brought a shift from the 'just in cast education' to 'just in time education' system. Internet, another cost-effective solution of reaching out to the learners at a distance, is gaining ground throughout the world. It is acting as a catalyst for change in the education process. It has taken education beyond the classroom and lecture hall into a new era of networked and collaborative learning. Since the aim of e-learning environment in education is to enhance students' learning opportunities by enabling them to partake in global, team based educational projects, in which they directly experience different cultural contexts and access a variety of digital information sources via a range of appropriate Information and communication technology, the future academic library professional should change their role by developing new standards and skills accordingly to meet the future digital information needs of the users.

Today almost all the academic institutions, universities and college libraries have been automated by library software and have become connected with Internet, intranet and extranet facilities and through which they are providing access to relevant e-journals and e-books by proxy-server based networks. So the future of the academic library services may be changed accordingly to fulfill the needs of the patrons in the e-learning environment. Libraries have an outstanding potential as the third place, after home and work with learning, inspiration and entertainment. Hence it is very essential to change the environment, structure and interiors of the academic libraries according to the digital information needs of the user and the future library should not have collection storage as its main function. E-learning opportunities must be enabled by the library professionals to the user in global level to access a variety of digital information sources via a range of appropriate World Wide Web technology. E-Learning is a catch-all term that covers a wide range of instructional material that can be delivered on a CD-ROM or DVD, over a local area network (LAN), or on the Internet. It includes Computer-Based Training (CBT), Web-Based Training (WBT), and Electronic Performance Support Systems (EPSS), distance or online learning and online tutorials. The major advantage to students is its easy access¹⁴. So, providing access to online e-journals and e-books through networks will enhance the self-learning knowledge of the user.

VI. TRENDS AND CHALLENGES BEFORE THE FUTURE ACADEMIC LIBRARY PROFESSIONAL IN THE E- LEARNING ENVIRONMENT

The first and foremost challenge before the library professionals to face the future



academic needs of the user in the e-learning environment is to provide electronic access to all relevant information and integrate it on networks across the world. The second challenge is to create a new physical library premises with computer network facilities, abandoning the old concept of library as a storehouse, and, the third challenge to future library professionals is to develop new standards and skills for the library profession to meet the user needs in a proactive way. In this e-learning and e-publishing environment, electronic reference services and other support services with various expertise and digital repositories are becoming a must.

The most pressing and pervasive issues and challenges that the library and information science professionals face in the present digital era for providing digital information service to the knowledge society are:

i) New generation of learners, ii) Copyright, iii) Privacy/Confidentiality, iv) Online/Virtual crimes and Security, v) Technology challenges, vi) Manpower, vii) Collection of digital e-resources, viii) Organizational Structure, ix) Preservation / archiving of digital e-resources, x) Lack of clarity in vision

i.) The New Generation of Learners

Today's students are grown up with latest information and communication technologies. They are coming to higher education with aptitude, knowledge and expectations that have been shaped by the use of the Internet, digital media, and portable communication technologies. Students often begin their search for information with Google or similar commercial or social search engines. The academic library professional must develop a virtual electronic learning system to enhance the student's knowledge and to accommodate an increasingly diverse group of users.

ii.) Copyright

An important issue that the present day library professionals are facing in providing electronic/digital information service is the large scale of piracy of software and plagiarism. The cost and timeliness in retrieving the information are also considered. When negotiating access with a publisher, the librarian must agree to certain restrictions on photocopying or distribution of electronic materials. Despite copyright notices and efforts to educate employees and users about intellectual property rights, electronic publications can be easily forwarded to people outside the licensed user group. The library is responsible for maintaining the awareness of all users about copyright issues.

iii.) Privacy/confidentiality

Maintaining privacy and confidentiality is another problem in accessing online information. To control pirating of software, copying or downloading all the contents of any e-resource at a time, right to obtain information and right to withhold or ban the access is essential and so there is a delicate challenge between privacy and rights to information. Now days almost all the users are having their own e-mail accounts and they are often sending and receiving important information and even secret programmes and databases through e-mail itself and storing them for future usage. So maintaining privacy from e-mails is a great

issue. Protecting one network from another to maintain confidentiality of information is another problem in securing databases on Internet and Intranet.

iv.) Online/Virtual Crimes and Security

“Privacy and security are two sides of the same coin,” said Kurtz. “If we can improve Web security, we will be able to have a positive impact on privacy as well.” Presently, Web/cyber crimes have become a common threat on internet. To overcome this issue, compulsory Virus Proof procedures should be adopted while downloading e-information from any other system. To secure the system from viruses, the databases can be modified by hacker proof procedures. Separate login and password systems are to be compulsorily adapted to the Network systems. In the LAN environment, the real danger is the gradual erosion of individual liberties through the automation, integration, and interconnection of many small, separate record- keeping systems, each of which alone may seem innocuous, and wholly justifiable. To overcome the above database security problems and issues, it is essential to install a database security software or firewall technology like Norton Anti-virus software and IBM e-network Firewall technology to protect the databases.

v.) Technology Challenges

Technology provides challenges to access information. The ALA’s 1995 Code of Ethics clearly states that everyone should have access to information. The recent explosion of information available on the Internet presents challenges to the traditional American Library Association (ALA) code of ethics that is taught in library school. Librarians make ethical decisions every day on the basis of the culture of their organizations. Some organizations limit access to particular levels of employees by requiring a username and password; others may institute behind-the-scenes filtering software or restrictive policies for providing access to the entire Internet. Because these steps challenge the very essence of librarianship, the librarian must step in and voice concern for the patron’s rights. Establishing well defined access policies will help to clarify who has access to the Internet, under what conditions, for what purposes, and with what restrictions. Policies should consider how to integrate the new technology and how its use reflects the objectives and values of the library.

vi.) Manpower Issues

Lack of skilled manpower to maintain the e-resources and to provide proper e-information service to the knowledge society is another main problem. Core competencies of library staff are expanding to include technology skills, personal skills, learning and teaching capacity, team skills, commitment to ethics, leadership skills, communication skills, creativity skills, designing and implementing skills etc. Hence library education must be redesigned to meet the new challenges and issues evolving in the knowledge society. Adequately skilled staff should be recruited to meet the increased demands of the knowledge society. With a rapidly changing environment both within and outside the library, staff development programs are crucial to the continued success of the organization.

vii.) Organizational Structure

Technology has broken down the rigid hierarchical structure of the organizations which is another important issue in changing the roles of the librarian in the knowledge society. Far from emulating the organization of conventional libraries, the organization and structure of digital libraries, and the division of labour within them, are open to considerable experimentation. For example, as publishers and professional societies disseminate works electronically, they are testing how far their investments should incorporate the full range of library functions, and the digital libraries license content from publishers and professional societies that manage their own repositories.

viii.) Collection of E-Resources

Collecting the materials and making it available to all current and future users is another core value of librarianship. The challenge is for the librarian to contribute to establish realistic collection-development policies covering acquisition of and provision of access to electronic resources for users now and in the future. With the increase in electronic resources, librarians and libraries are no longer just collecting and caring for print materials. Unlike a print book or a journal, electronic resources cannot be considered a permanent addition to a collection. Payment for a product covered by a license is a payment to use the information product for a period of time that is usually specified in a contract. This payment is not for the outright purchase of the product or for ownership of all the rights to that product. A digitized collection means that libraries share the use of the collections with other institutions, not only locally, but also globally. It is the publisher who dictates how much access will be provided, which issues will be available, and how much that access will cost.

ix.) Preservation/Archiving of E-Resources

To preserve the e-resources for access would be a contradiction in an electronic environment for librarians, where there is unlimited and continuous access, but performance is not there in such an environment. This leads to the conflict on what is to be preserved and what is to be accessed. If we need to preserve electronic resources/documents, we need to preserve all the software and hardware also to read the documents that we create. Currently, there are two radically different solutions for preserving digital information: migration and emulation. Neither solution is without some risk. Migration may not work for specialized, proprietary formats. It may save the content of a file but lose or diminish the internal relationships or contexts of the information. The second strategy, emulation, assumes future access to multiple data objects. If one or more of the components were missing, this complex environment would most likely fail.

Distribution and archiving through digital repositories will insure that the library has a viable system for sustaining digital content. Digital repositories also will facilitate the long term conversion and preservation of print materials, and create new opportunities to structure learning activities around the content.

x.) Lack of Clarity in Vision

The biggest challenge that the librarians are facing in the knowledge society, seems to be lack of clarity in vision and a general lack of direction. A general vision is needed and

the general integrated plan should be shared among the library professional, which should bring unity of purpose. The Library professional should become capacity builders and facilitators to the knowledge society. The vision of the library professionals should emphasize on the quality of services provided to support teaching, research and public service activities, to enable the users to become self sufficient and to make the library both a place and gateway for accessing information within and beyond the walls of the library.

xi.) Impact of Web-based E-Learning Systems

The emergence of web-based e-learning systems through Internet facility has great impact on every facet of library activities and information services. Library and information professional of the future academic libraries face the following paradigm shifts due to the rapid developments in the ICT and WWW technologies:

- Transition from procuring and managing print media to electronic media Changes from passive user to active user in the e-literacy environment
- Concept of web-based networked environment
- Disseminating information on demand to proactive digital information services
- Providing information service to facilitating access to e-information service
- Transition of developing the normal collection to e-resources (e-books and e-journals)
- Individual works to team works.

VII. CHANGING ROLE OF FUTURE ACADEMIC LIBRARY PROFESSIONAL

The changing role of library professional implies a set of updated skills needed for facing the challenges created by the latest web technologies in the e-learning environment. The emphasis will shift from technical skills in the library to communication, facilitation, training and management skills. Although technology presents the librarian with ethical challenges, the librarian is to be ready for the role of information professional in the connected networked world and they have to acquire skills that can be contributed to success in their new roles.

i.) Leadership Role

One primary role of librarians is to provide leadership and expertise in the design, development, and ethical management of knowledge-based information systems in order to meet the information needs and obligations of the patron or academic institution. In the future, as now, we can expect the virtual library to be the organization that identifies, selects, negotiates for, and provides access to an incredible range of information resources on our behalf. At present, lot of virtual libraries have been created and managed by various institutions and organizations for e-learning and teaching professional. Hence library professional should enrich their management skills to play leadership role in the digital future, for organizing, managing and disseminating e-literacy to users.

ii.) Proactive Information Professional Role

The modern trend is for the role of the librarian to move from that of a passive intermediary role responsible for guiding patrons to appropriate information resources,

towards that of a much more proactive professional role which includes analyzing and repackaging information, content information management systems and institute digital repository management systems.

iii.) **Role of Librarians as Masters of Web**

To face the challenges of the virtual learning environment in educational institutions, librarians are becoming masters of the Web. Librarians create powerful web sites such as the National Library of Medicine's PubMed database. They create their own website as an easier way to share with others what they know. They gather electronic information and create electronic pathfinders and front-end search tools to help users for accessing the required information. Academic Library professionals create online tutorials and instructional web pages to help patrons for performing the best searches. They provide links to websites on specific topics and lead patrons to these evaluated sites as a starting point for retrieving related and relevant information.

iv.) **Role of E-Resource Managers**

Academic and research libraries have a major role in ensuring that they and their home institutions remain vital players in the changing terrain of information and education. Faculty may not aware of copyright issues and do not know what material is electronically available or licensed by the library. Virtual learning systems can be connected to library systems, through the integration of library systems at the back end via the technology components, and through the close liaison and involvement of library staff in VLE development, i.e. the human component.

VIII. CONCLUSION

The remarkable growth of Internet has made significant revolution in all the areas of science and technology. Rather than using it as a tool for searching and retrieving information, Internet has become the king of all media, by which we can access virtual information and can build a virtual library to provide timely, quality service to the users. Librarians of this digital era, are in the position to change their role as arbitrary information scientists/gatekeepers and to meet the challenges of the Internet, World Wide Web, online access in the knowledge society. So they must enrich their knowledge with special skills of the latest IT developments, to browse, access and retrieve a particular information across the global networks and to organize and manage the information by building digital libraries and by which they can provide quality e-information service to the knowledge society. Library staff must be capable of working effectively in partnership with faculty members to enhance the strength of teaching and research. To be certain, there are many staff members of this kind in academic libraries today. In this as in other respects, part of the skills, library staff must develop is the ability to educate faculty members, helping them to understand the power and applicability of e-resources.

IX. REFERENCES

- [1] Abbott, Andrew. (1998). Professionalism and the Future of Librarianship. *Library Trends*, 46.3, 430- 445.

- [2] Allen, Michael W. (2003). *Michael Allen's guide to elearning*. John Wiley.
- [3] Arant, Wendi and Benefiel, Candace R. (2003). *The image and role of the Librarian*. Haworth Press.
- [4] Bonk, C. (2004). The Perfect E-Storm: emerging technology, enormous learner demand, enhanced pedagogy, and erased budgets. *Observatory on Borderless Higher Education, Reports*, June.
- [5] Dewey, Barbara. (2004). The Embedded Librarian: Strategic Campus Collaborations. *Resource Sharing & Information Networks* 17.(1/2), 5-17.
- [6] Professional in the E-Learning Environment : Challenges and Issues, , ICAL 2009 – Vision and Roles of the Future Academic Libraries. p.140.
- [7] Dugdale, Christine. (1999). The role of electronic reserves in serving and shaping new teaching and learning environments in UK universities. Thamaraiselvi.G, Vision and the Changing Roles of the Future Academic Library

To Cite This Article

Biradar, S.G. (2016): “Changing Role Of The Future Academic Library Professional In The E-Learning Environment - Challenges And Issues” *International Journal of Informative & Futuristic Research (ISSN: 2347-1697)*, Vol. 4 No. (4), December 2016, pp. 5881-5890, Paper ID: IJIFR/V4/E4/031.

AWARENESS TOWARDS GOODS AND SERVICES TAX IN INDIA

Paper ID	IJIFR/V4/ E4/ 030	Page No.	5891-5896	Research Area	Commerce
Index Terms	Goods and Services Tax (GST), Indian government, Awareness, Implementation				

Jatin

Assistant Professor
Department of Commerce
Dayanand College, Hisar (Haryana)

Abstract

One of the main sources of governments' revenue is collection from taxes. Goods and Services Tax (GST) is one of several taxes that may make significant contribution in governments' income. The Goods and Services Tax (GST) is a value added tax to be implemented in India, on which the decision is still pending. However, Indian Government is still waiting for the right time to implement GST because it is still doing surveys to ascertain the social impact of GST. This study attempts to examine awareness among Indian masses towards the implementation of upcoming GST that is proposed to be implemented in India starting from April 1, 2017. This study aims at measuring the level of people satisfaction and attitudes towards the implementation of GST. This paper is an analysis of the impact of GST in Indian Tax Scenario.

I. INTRODUCTION

The present structure of Indirect Taxes is very complex in India. There are so many types of taxes that are levied by the Central and State Governments on Goods & Services. We have to pay 'Entertainment Tax' for watching a movie. We have to pay Value Added Tax (VAT) on purchasing goods & services. And there are Excise duties, Import Duties, Luxury Tax, Central Sales Tax, and Service Tax. As of today some of these taxes are levied by the Central Government and some are by the State governments. How nice will it be if there is only one unified tax rate instead of all these taxes¹?

1.1 What is GST?

It has been long pending issue to streamline all the different types of indirect taxes and implement a "single taxation" system. This system is called as GST (GST is the abbreviated

¹ <http://www.relakhs.com/gst-goods-services-tax-in-india/>

form of Goods & Services Tax). The main expectation from this system is to abolish all indirect taxes and only GST would be levied. As the name suggests, the GST will be levied both on Goods and Services.

GST was first introduced during 2007-08 budget session. On 17th December 2014, the current Union Cabinet ministry approved the proposal for introduction GST Constitutional Amendment Bill. On 19th of December 2014, the bill was presented on GST in Loksabha. The Bill will be tabled and taken up for discussion during the coming Budget session. The current central government is very determined to implement GST Constitutional Amendment Bill. GST is a tax that we need to pay on supply of goods & services. Any person, who is providing or supplying goods and services, is liable to charge GST.

1.2 How is GST applied?

- GST is a consumption based tax/levy. It is based on the “Destination principle.” GST is applied on goods and services at the place where final/actual consumption happens.
- GST is collected on value-added goods and services at each stage of sale or purchase in the supply chain. GST paid on the procurement of goods and services can be set off against that payable on the supply of goods or services. The manufacturer or wholesaler or retailer will pay the applicable GST rate but will claim back through tax credit mechanism.
- But being the last person in the supply chain, the end consumer has to bear this tax and so, in many respects, GST is like a last-point retail tax. GST is going to be collected at point of Sale.

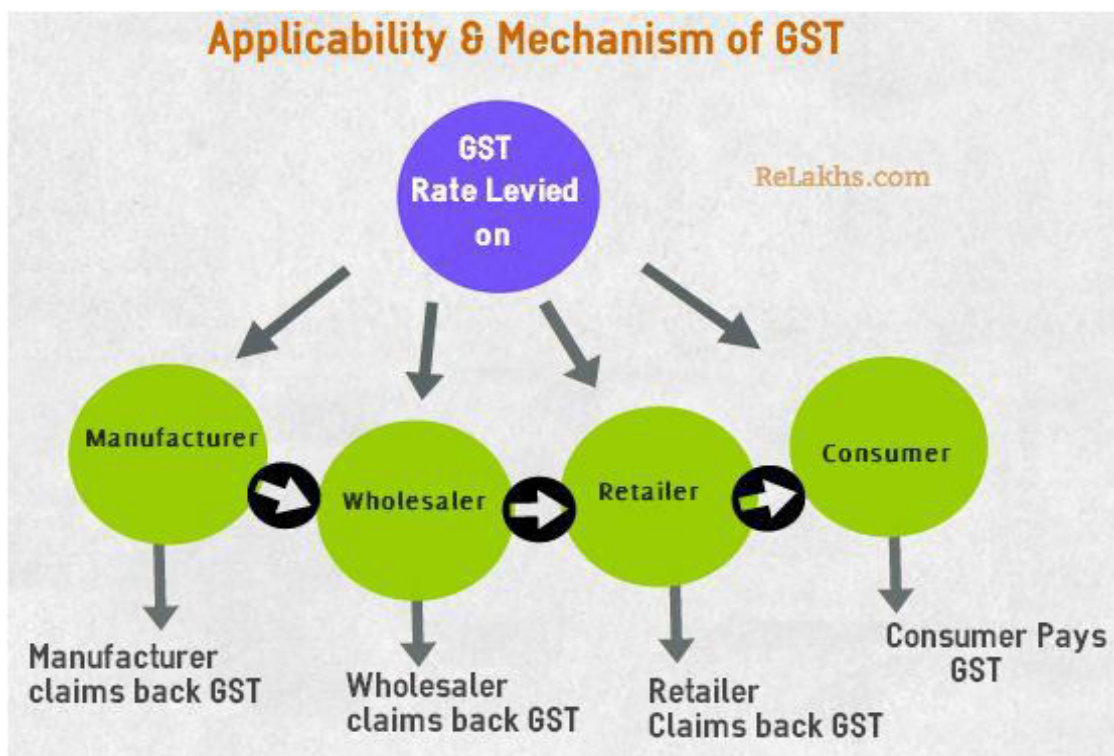

Figure 1: Applicability & Mechanism of GST

Source: <http://www.relakhs.com/gst-goods-services-tax-in-india/>

Let us understand the above supply chain of GST with an example:

GST Supplychain example (Assuming GST rate @ 8%)				
Supply of Goods	GST Flow	Input Costs (ex-GST)	Sale Price (ex-GST)	GST Collected
A weaver sells a fabric to a tailor for Rs 108 per metre	The weaver pays GST of Rs 8	0	Rs 100	Rs 8
The tailor sells a ready made completed shirt to a retailer for Rs 270	The tailor pays GST of Rs 12 (After input tax claim. Weaver claims tax credit for Rs 8)	Rs 100	Rs 250	Rs 12
The retailer sells the readymade shirt in his showroom for Rs 540	The retailer pays GST of Rs 20 (After input tax claim. Tailor claims tax credit for RS 12)	Rs 250	Rs 500	Rs 20
You purchase the shirt for Rs 540	No Tax credit claim. You pay entire GST Rs 40 @ 8%	NA	NA	Total : Rs 40

www.relakhs.com

Figure 2: GST Supply Chain

Source: <http://www.relakhs.com/gst-goods-services-tax-in-india/>

II. OBJECTIVE OF THE STUDY

- 1) To study the collection mechanism tax under GST regime
- 2) To find out level of public awareness on Goods and Services Tax in Hisar

III. RESEARCH METHODOLOGY

The study presents the statistical analysis of 130 respondents from Hisar. It measures the public perceptions towards goods and services tax (GST). A total of 150 sets of survey were distributed within the Hisar but only 130 were returned and valid. The data are later analysed using multiple regression and descriptive analysis. Multiple regression analysis was used to test the cause of relationship among independent variables with people's awareness on GST.

IV. DATA ANALYSIS

Table 1 below is the summarization of descriptive statistics performed. Panel A reported that 85 percent of respondents are male while female only accounted a percentage of 15. Panel B showed that most of the respondents are from the age group of 20 – 30 years old, charting a percentage of 45, followed by 31 – 40 years old (28 percent), 41 – 50 years old (18 percent) and above 50 years old (9 percent).

Table – 1 Descriptive Statistics

Panel A		
Gender	Male	Female
Frequency	110	20

Percentage	85		15	
Panel B				
Age	20-30	30-40	40-50	Above 50
Frequency	58	36	24	12
Percentage	45	28	18	9
Panel C				
Qualification	10+2	Graduate	Post Graduate	PhD
Frequency	33	59	28	10
Percentage	25	45	22	8
Panel D				
Income	Less 10000	10000-20000	20000-30000	Above 30000
Frequency	26	53	34	17
Percentage	20	41	26	13
Panel E				
Occupation	Businessman	Professional	Students	Employee
Frequency	63	20	12	35
Percentage	48	15	9	27

- Panel C showed majority of the respondents holds a Degree qualification with a percentage of 45, followed by 22 percent with a Master, followed by 25 percent with 10+2 and 8 percent with a PhD.
- Panel D clearly shown that the respondents (20 percent) have an income level of less than 10000, followed by those with an income level of 10000 – 20000 (41 percent), 20000-30000 (26 percent) and those 30000 and above (13 percent).
- Panel F exhibited 48 percent of the respondents are businessman, followed by 15 percent are Professionals, 27 percent are Employees and 9 percent are students.

4.1 MULTIPLE REGRESSION ANALYSIS

Table 2: Model Summary

Model	R	R Square	Adjusted R Square	Std. Error of the Estimate
1	.866 ^a	.750	.729	.473

Predictors: (Constant), x10, x4, x2, x3, x1, x8, x9, x6, x7, x5

Table 3: Coefficients of Satisfaction Function of GST

Model	Unstandardized Coefficients		Standardized Coefficients	t	Sig.
	B	Std. Error	Beta		
(Constant)	1.791	.289		6.199	.000
x1	.213	.145	.220	1.473	.143

x2	-.150	.176	-.133	-.850	.397
x3	.109	.139	.130	.784	.435
x4	.119	.134	.112	.883	.379
x5	.341	.192	.440	1.782	.077
x6	.073	.183	.093	.399	.690
x7	-.415	.178	-.442	-2.333	.021
x8	1.214	.130	1.484	9.323	.000
x9	-.942	.147	-1.115	-6.395	.000
x10	-.161	.148	-.184	-1.088	.279

a. Dependent Variable: S

The results indicate that 75 percent of the variation in the dependent variable, i.e. satisfaction, is explained by the set of 10 independent variables. The variable X₇, X₈ and X₉ are significant variable. The coefficient of the variable X₉ indicates that the public do not perceive GST to be better than when GST is introduced the price of product will become reduced and that has resulted in a negative and significant coefficient of the variable. This shows that the GST can perceive price of product will become reduced as a potential threat. Further, the variable X₇ that GST also reduces much paperwork as a negative sigh, which is surprising. Moreover, the coefficient of this variable is significant. Similarly, the eighth variable, that GST prevention of unhealthy competition among states, is significant and positive. This shows that this variable is very important and contributing to the satisfaction of the public. Therefore, the government should try to cash on this and this should be reflected in their awareness programmes. All other variables have correct signs.

V. CONCLUSION

The issue of GST is being discussed much recently. Indian Government proposing to implement GST as a tool to increase its revenue and reduce its deficit. An earlier plan by the government was to implement GST in the beginning of April 2017; however this plan was being deferred. Findings of this study show that the level of awareness among Indians is still relatively low. Is could be due to the lack of knowledge or information regarding GST. For this reason, the government should reflect on how to increase the knowledge of GST among citizen. Furthermore, they should put more effort in delivering information and educating the citizen regarding GST, so that the citizen will have positive view about this GST implementation. The results revealed that all of these independent variables were found to have significant impact toward the publics’ awareness on Goods and Services Tax (GST).

VI. RECOMMENDATION

The level of education could also affect the publics’ awareness on tax. As for now, the fact that basic tax education is not currently taught in any schools or higher institutional, the

publics' general knowledge of tax are low. It is suggested that government to make an effort to provide or add subject about basic taxation as main subject at schools to educate students at an early age and also the teachers. This could improve their tax knowledge, tax morale, and could change their perception towards the tax (Nasir, N. B., Abdullah Sani, A. B., Mohtar, N. M., & Zainuridin, Z. K., 2015).

VII. REFERENCES

- [1] Ishak, N. I., Othman, M. H., & Omar, M. F. (2015). Students' Perception towards the Newly Implemented Goods and Services Tax (GST) in Malaysia. *International Journal of Contemporary Applied Sciences* , 2 (6), 88-99.
- [2] Saira, K., Zariyawati, M. A., & May, L. Y. (n.d.). An Exploratory Study of Goods and Services Tax. *Political Management and Policies in Malaysia* , 265-276
- [3] Nasir, N. B., Abdullah Sani, A. B., Mohtar, N. M., & Zainuridin, Z. K. (2015). Public Awareness Towards Goods and Services Tax (GST) in KUALA LUMPUR, MALAYSIA. *International Academic Research Journal of Social Science* , 1 (2), 101-106.
- [4] Chong, K. F. (2006). Towards goods and services tax in Malaysia: a preliminary study. 1-17.
- [5] Kanimozhi, N. (2013). An analysis of the perception of value added tax (VAT) in Tamilnadu. *Indian Journal of Applied Research*. 9(3), 103-105.
- [6] Simon James, C. A. (2002). Tax compliance, self-assessment and tax. *Journal of Finance and Management in Public Services*, 27-42.
- [7] Pauline Niemiowski, S. B. (2003). Tax Related Behaviour, Beliefs, Attitudes, and Values and Taxpayer Compliance in Australia. *Australian Taxation*, 132-165.
- [8] Mohd Rizal Palil, M. R. (2013). The Perception of Tax Payers on Tax Knowledge and Tax Education with Level of Tax Compliance:.. *ASEAN Journal of Economics, Management and Accounting*, 118-129.
- [9] Mohd Rizal Palil, M. A. (2011). The Impacts of Goods and Services Tax (GST) on Middle Income Earners in Malaysia. *World Review of Business Research*, 192-206.
- [10] Mir Behnud Djawadi, R. F. (2013). The Impact of Tax Knowledge and Budget Spending. 54-76.
- [11] Ling, C. K. (2006). Towards Goods and Services Tax in Malaysia: A Preliminary Study. *Business & Economics Society International* (pp. 75-85). USA: B&ESI.
- [12] Lin Mei Tan, C. C. (2000). The Impact of Tax Knowledge on the Perceptions of Tax Fairness and Attitudes towards Compliance. *Asean Review of Accounting*, 44-58.
- [13] Junainah Jaidi, R. N. (2013). Individual Taxpayers' Perception towards Self-Assessment System: A Case of Sabah. *Asian Academy of Applied Business*, 56-65.
- [14] Dusa Sumartaya, A. H. (2014). The Influence of Taxpayer's Awareness and Tax Morale toward Tax Evasion. *Business Economics and Law*, 60-68.
- [15] Asma Moomal, Z. Z. (2014). Awareness, Acceptance and Expectations of Malaysian Consumers towards Goods and Services Tax (GST). *Journal of Contemporary Management Science*, 15-27.
- [16] Ammanuddin Shamsuddin, M. I. (2014). Educators' Awareness and Acceptance towards Goods and Services Tax (GST) Implementation in Malaysia: A Study in Bandar Muadzam Shah, Pahang. *Economics and Law*, 1-9.

DISTRIBUTED REFLECTION DENIAL OF SERVICE ATTACK USING CORRELATION MATRIX

Paper ID	IJIFR/V4/ E4/ 036	Page No.	5897-5900	Research Area	Network Security
Index Terms	Rank Correlation, RCD, Distributed Reflection, Network Security, Denial of Service				

1 st	Vikas More	Student Department of Computer Engineering S P College of Engineering, Otur,Pune
2 nd	Gajanan Deokate	Assistant Professor, Department of Computer Engineering S P College of Engineering, Otur,Pune

Abstract

Denial of service attack in computing involves blocking of resources to particular user. This kind of blocking may be temporary or indefinite blocking to access resources in the network and detection strategies are failing to solve this issue. This paper mainly concentrates on determining correlation between packet flow and using it to detect DR-DOS attack. Correlation can be used for determining network flows for suspicious behaviour. Although multivariate correlation analysis is computationally expensive but it only matter at the time of training the system, thereafter there is less overhead on computation. This system highly accurate and is a protocol independent method.

I. INTRODUCTION

Distributed Denial of Service (DDoS) attack is a very big issue in the internet today. In DDoS attack, the attacker sends a large number of packets towards the victim to take down the resources and services provided by the victim to its users. The DR-DoS attack is the superior one to the DDoS attack; in DR-DoS the attackers sends malicious packets requests to the innocent servers (nodes) within the network and pretend them that those are the normal data packets. As the innocent nodes treat these malicious packets as normal packets, these packets are reflected towards the victim in large number of reflected flows. The server cannot differentiate by itself between the normal and attacking flows and after some time



goes down [1]. Detecting the malicious flow nearby a single reflector is not helpful because the traffic coming out from a single node is negligible. The different computational techniques can be used to detect the attacks but it requires more time for performing the calculations on each of the flow and then detecting it. Each of the different protocol is based on the different technique, so there should be some single counter measure which detects the DR-DoS with different protocols. So we can use a protocol independent method for detection of the DR-DoS attack i.e., correlation based detection [2][3]. We analyse the traffic pattern nearby the victim and use the flow correlation based detection method. This is a protocol independent technique and also it does not affect the network throughput during the computation [8].

II. LITERATURE SURVEY

Intrusion Prevention System: Intrusion prevention Technique which can be efficiently used to detect the DR-DoS attack. An intrusion prevention technique which follows a combination of one or more number of detection mechanisms it includes signature based detection, firewall based prevention, and Anomaly based detection [2] [12].

- i.) **Signature Based Attack:** In computer network, the traffic of the network is monitored along with signature pattern. The attacks pattern is compared with help of signature database. The database encloses one or more number pre-defined signatures. If the traffics match with database signature traffic it will take necessary steps to block the attacks [2].
- ii.) **Firewalls:** Firewalls are one of the methods of Intrusion Prevention System. The main idea of using firewall within the environment to impose endeavour strategy and preserve association state information for genuine users both internally and also externally and not to prevent high volume DDoS / DRDoS style attacks [2][12].
- iii.) **Anomaly based Detection:** Anomaly based detection is supposed to be a profile based signature monitors system. It observes the network traffic continuously .If the traffic mismatches the existing normal traffic. It consider as an attack. And its blocks the concurrent networks to prevent a DDoS attack [2].
- iv.) **Fuzzy Based Technique:** Fuzzy is a software tool to test the end user application and protocols. Each time there is a situation to implement a new protocol or software or any application. It must be tested with fuzzy tools. The tool will decide whether it can be implemented in real-time and it weather it is a secure one or not [17]. **Filter based approach:** Flow level filter is used to detect the low rate DDoS attack. Low rate DDoS attack which gradually increase the traffic rate and attack the network host. Flow level filter which blocks the DDoS attacks [8] [13].
- v.) **Hiroshi Tsunoda, Kohei et.al [10]** proposed work on detecting DRDoS attacks by a simple response packet confirmation mechanism Response packet confirmation mechanism. His proposed model was simple to deploy and computational cost is also low. **Basheer Al-Duwairi et.al [11]** proposed distributed packet pairing for reflector based DDoS attack mitigation. The advantage of this type of model was

distributed packet pairing far situated malicious packets can be detected. Wei Wei, Feng Chen et.al [1] proposed Rank Correlation based Detection against Distributed Reflection DoS Attacks. A Rank Correlation based Detection Efficiently differentiate attack packets from the malicious packets. Mohana Priya P et.al [12]. Reeta Mishra et.al [13] Anticipation methods from DR-DoS attack Anticipation methods Good accuracy.

- vi.) **Rupa Rani et.al [14]** CARD (Continuous and Random Dropping) based DRDOS Attack Detection and Prevention Techniques in MANETCARD (Continuous and Random Dropping If the queue length exceeds the maximum threshold value, then the packets drop continuously. Xiao, Bin et.al [9] proposed a novel approach to detecting DDoS Attacks at an early stage Cooperative based detection method warning will be sent to the protected server, if packet drop occurs.

III. PROPOSED SYSTEM

The framework works in two stages. In first stage training data is given to system that in turn looks for patterns from the input data. In the second stage called detection, various packets are given to the system in which system uses previously calculated normal profile behaviour and threshold given for DR-DoS, attack detection. For generating normal profile we used correlation analysis method, it uses statistical technique to determine the correlation between various attributes altogether.

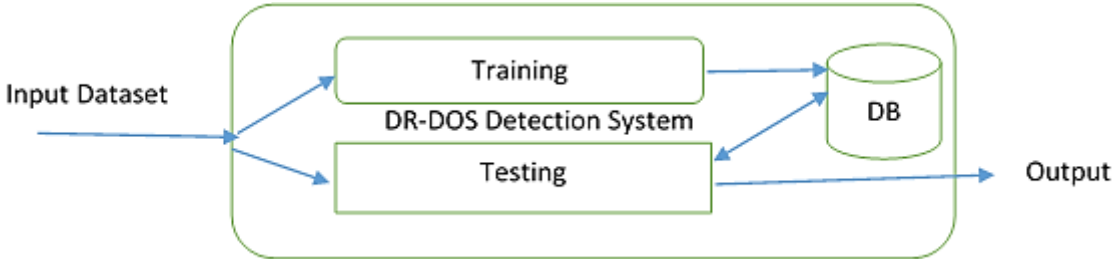

Figure 4.1: System Architecture

Algorithm 1: Finding normal behaviour of traffic records,

- Step 1: Input network traffic records.
- Step 2: Extract original features of individual records.
- Step 3: Calculate correlation matrix.
- Step 4: Store normal profile parameters such as standard deviation, mean.

Algorithm 2: Attack Detection.

- 1. Input: observed traffic, normal profile and alpha.
- 2. Generate TAM for i/p traffic
- 3. Calculate MD between normal profile and i/p traffic
- 4. If MD < threshold
- 5. Detect Normal
- 6. Else
- 7. Detect attack.

IV. CONCLUSION

DR-DoS attacks are a growing problem. The Solution concentrates on detecting DR-DoS independent of specific protocols using the Correlation based Detection algorithm. We also discussed possible correlation based detection method for detecting DRDoS attacks. There are a lot of interesting works in the future, including: Extend the experiment against real DR-DoS in the Internet. The algorithms can be used in more complicated network scenario which uses many routers. Include tracing methods to find the attacker for better avoidance of the attack

V. REFERENCES

- [1] Wei Wei, Feng Chen, Yingjie Xia, and Guang Jin “A Rank Correlation Based Detection against Distributed Reflection DoS Attacks”, IEEE Communications Letters, Vol. 17, no. 1, January 2013. .
- [2] Lei Zhang, Shui Yu, Di Wu and Paul Watters “A Survey on Latest Botnet Attack and Defense”, 2011 International Joint Conference of IEEE TrustCom-11/IEEE ICSS-11/FCST-11.
- [3] Vern Paxson, “An Analysis of Using Reflectors for Distributed Denial-of-Service Attacks”, Computer Communication Review 31(3), July 2001. .
- [4] “Detecting Distributed Denial of Service Attacks Using Source IP Address Monitoring”, Tao Peng, Christopher Leckie, Kotagiri Ramamohanarao, In Proceedings of the Third International IFIP-TC6 Networking Conference(2002).
- [5] Yonghui Li, Yulong Wang, Fangchun Yang, Sen Su , “Traceback DRDoS Attacks”, Journal of Information & Computational Science 8: 1 (2011) 94–111 .
- [6] T. Hiroshi, O. Kohei, and Y. Atsunori, “Detecting DRDoS attacks by a simple response packet confirmation mechanism,” Computer Commun., vol. 31, no. 14, pp. 3299–3306, 2008
- [7] T. Vogt, “Application-level reflection attacks.” Available: <http://www.lemuria.org/security/application-drdos.html>
- [8] S. Yu, W. Zhou, W. Jia, S. Guo, Y. Xiang, and F. Tang, “Discriminating DDoS attacks from flash crowds using flow correlation coefficient,” IEEE Trans. Parallel Distrib. Syst., vol. 23, no. 6, pp. 1073–1080, 2012.
- [9] B. Xiao et al., “A novel approach to detecting DDoS Attacks at an Early Stage”, The Journal of Supercomputing, vol. 36, no. 3, 2006, pp. 235-248.
- [10] H. Tsunoda et al.,” Detecting DR-DoS attacks by a simple response packet confirmation mechanism”, Computer Communications, vol. 31, no. 14, 2008, pp. 3299-3306.
- [11] B. Al-Duwairi and G. Manimaran, “Distributed packet pairing for reflector based DDoS attack mitigation”, Computer Communications, vol.29, no.12, 2006, pp.2269-2280.
- [12] P. Mohana Priya et al., “The Protocol Independent Detection and Classification (PIDC) System for DR-DoS Attack”, Fourth International IEEE Conference on Recent Trends in Information Technology (ICRTIT), 2014.
- [13] R. Mishra, “Anticipation methods from DR-DoS attack”, VSRD International journal of Computer Science and Information Technology, vol.2, no.11, 2012, pp. 890-894.
- [14] R. Rani and A.K. Vatsa, “CARD (Continuous and Random Dropping) based DRDOS Attack Detection and Prevention Techniques in MANET”, International Journal of Engineering and Technology, vol.2, no. 8, 2012, pp.1449- 1456

To Cite This Article

More, V., Deokate, G. (2016): “Distributed Reflection Denial Of Service Attack Using Correlation Matrix” *International Journal of Informative & Futuristic Research (ISSN: 2347-1697)*, Vol. 4 No. (4), December 2016, pp. 5897-5900, Paper ID: IJIFR/V4/E4/036.

COTTON CROP DISEASE DETECTION AND DIAGNOSIS USING IMAGE PROCESSING TECHNIQUE

Paper ID	IJIFR/V4/ E4/ 037	Page No.	5901-5906	Subject Area	E &TC Engineering
Index Terms	Image Processing Technique, Agricultural Usefulness, Artificial Neural Network, Biomedical Image Processing, Feature Extraction Technique				

1 st	Durgesh M. Naik	PG Student Department of Elec. & Telecomm. Engineering P.E.S's Modern College of Engineering , Pune
2 nd	Dr. Arati J. Vyavahare	Professor, Department of Elec. & Telecomm. Engineering P.E.S's Modern College of Engineering , Pune

Abstract

Cotton is immensely important crops for sustainable economy of India and livelihood of the Indian farming community. Evaluation and diagnosis of crop disease is very critical in increased production. Some of diseases like foliar, Alternaria, Red spot, Bacterial blight, etc are the major important fungal diseases of cotton leaf that directly affect the production of cotton. The goal of this project is to developed advance computing system that can identify the disease affected part of cotton leaf spot by using image analysis technique. This project is based on latest technique of mobile that captured symptoms of cotton leaf spot images and categorise using proposed Algorithm. It helps to identify type of disease of cotton. Image RGB feature ranging technique is also used to classify diseases. Edge detection segmentation technique is going to be used for leaf spot diseases. The technique like labelling algorithm, structural elements is used to identify the edges. Later, Image features such as shape, boundary, colour and area, perimeter are extracted for disease spots and neural network is trained. As a part of diagnosis not only the pest recommendation but also information related to cotton is provided. This project is useful for government of agriculture, NGO related to agriculture, pesticide dealer as well as farmer.

I. INTRODUCTION

Cotton (*Gossypium* spp.) is a crop of warm climate and requires regular supply of water, either natural in the form of rainfall or assured through canals from the above surface and from underground source. Even though cotton is not a water having plant as like rice, it require a regular bring in of water for maintaining growth and balance between vegetative and reproductive phase. About 55% of the world cotton area is under irrigation and the balance is rained. Contrary 70 per cent of the cotton cultivated area in India is under rained conditions. Water stressed seed or plant, will have poor growth leading to low yield as well as exposure to diseases. In India, the cotton is being grown in three distinct zones viz., North (Punjab, Haryana, Rajasthan and few thousand acres in Utter Pradesh), Central (Gujarat, Maharashtra and Madhya Pradesh) and South (Orissa, Andra Pradesh, Karnataka and Tamil Nadu). In the North, Cotton is sown during April-May, in Central June-July and in South July-August. In Tamil Nadu, the summer cotton and rice fallow cotton are sown during January-February. In view of the differing agro-climatic conditions, the prevalence of spot also varies. All the four refined species of *Gossypium* are affected by different diseases. Only are specific to individual zones. Few diseases are common for all regions and the rest.

Since the quality cotton crop remains in the field for nearly six months or more, it is affected by various diseases caused by organisms such as fungi, bacteria and viruses that grow on and within the plant tissues. These organisms often cause stunting of the plant life, defoliation, abridged yield and sometimes demise. Seeds and seedling attack by these pathogens often die, while older plants usually survive but execute defectively. Disease can also be cause by environmental changes such as too much or too little of water or fertilizer, air pollutants and chemical injury such as those caused by herbicides and their residues. The diseases caused due to environmental changes become localized and do not spread where as diseases caused by organisms are contagious and can be spread by wind, water or vectors. We discuss here some of the important diseases which affect the quality cotton caused (Table 1) and their management through an integrated

1. **Alternaria leaf spot - Alternaria macrospora, A. Alternaria:** Alternaria macrospora causes brown, grey brown or tan lesions 3–10 mm in diameter, especially on lower leaf. With dark/purple margins and with concentric zones. Affected leaf develops an abscission layer, senescence and drop to the ground. Circular dry brown spot up to 10 mm across may also be seen on the bolls. A. Alternaria causes usually purple specks or small lesions with purple margins on leaves and bolls.
2. **Verticillium Wilt:** It is one of the diseases affecting cotton in Tennessee. It is the more damaging of the two wilts that happen on cotton. This disease is there in the cotton-growing area and is most severe during cool, wet growing seasons. Verticillium wilt is caused by the soil-borne fungus, Verticillium dahliae. This fungus can survive in the soil for many years, even in the absence of cotton. Cotton seedlings infected with Verticillium usually turn yellow, dry out, and die. Plants which become infected later in the season are stunted and exhibit a yellow condition along the leaf margins and between the main

veins. This yellowing imparts a spotted appearance to the plant. Severely affected plants will shed their leaves.

3. **Grey Mildew:** This disease primarily appears on older leaves as the plants attain middle age, in the form of unevenly angular, light spots, usually 3-4 mm in width and The lesions are light to yellowish green on the higher surface. As the spots raise grown-up, the leaves tissues turn yellowish brown while a whitish frosty growth appears chiefly on the under surface but occasionally also on the upper surface.
4. **Red Spot:** The Red Spot is very danger disease of cotton, leaf of cotton due to this disease automatically turns red in color, it destroy whole plant, due to this disease plant will lose production. The application of the computer in agriculture research originally exploited for the conversion of statistical formula or complex model in digital farm for easy and accurate calculation which are found relatively tedious in manual calculation. In the next generation, the same computers have been used to automation, computerization and to develop judgment support system for taking strategic decision on the agricultural production and security research. In recent times remote sensing and geographic information system has place a major and crucial role in agriculture research especially in the field of yield guess, appropriateness of soil for particular yield, and site specific source allotment of agriculture key in, etc.

II. RELATED WORK

On cotton crop so much work is completed, the technique is as follows,

- P. Revathi M. Hemalatha detected Cotton leaves spot diseases in [1] by using Homogenous pixel counting based Edge Detection Techniques. This algorithm is analysed with more types of cotton. In these work symptoms of cotton spot images are captured by mobile and classification is done by using neural network.
- Ajay. A, et al., (2012) this work addresses that disease analysis is possible for the cotton leaves disease. The investigation of the various diseases there on the cotton leaves can be effectively detected in the early stage before it will injure the whole crop. Initially we are able to detect three types of diseases of the cotton leaves by the methodology of Eigen feature regularization and extraction technique.
- Bernardes A. A. et al., (2011). This method proposed for automatic classification of cotton diseases through feature extraction of leaf symptoms from digital imagery. Wavelet transform has been used for feature extraction while SVM has been used for classification. Yan Cheng Zhang et al., (2007) the proposed paper discussed the fuzzy feature selection approach -fuzzy curves and Fuzzy surfaces are to select features of cotton leaf disease.

The feature extraction for classification of rice leaf diseases is processed in the following steps: firstly images acquired of diseased rice leaves from fields. Secondly preprocessing the images to remove noise from the damaged leaf and then enhanced the quality of image by using the [mean filtering technique. Thirdly Otsu's segmentation algorithm was applied to extract the infected portion of the image, and then radial hue distribution vectors of the segmented regions computed which are used as feature vectors.

III. SCOPE OF RESEARCH WORK

The main objective of this research work to increase the production of cotton crop by detection and diagnosis of that disease. This will lead to increase economy of related farmers as a result.

IV. PROPOSED METHOD

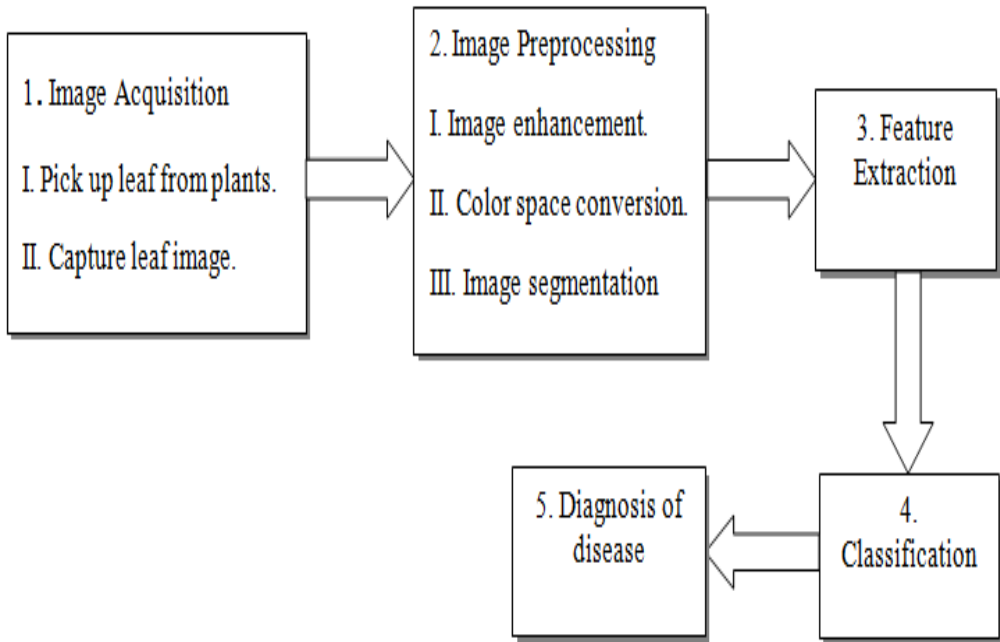

Figure 1: Basic Methodology

The block diagram showed above clear the all about concept of research work. In this first the normal image is captured that is these RGB image of respected leaf of cotton, then the preprocessing process is going to be following in that image enhancement process is done then color space conversion is in process masking of leaf is completed for image segmentation the geometrical operation. In the process of feature extraction technique the shape, size, color extraction is done then the accurate result is given by system

4.1 Description of the Proposed Algorithm:

- 1) RGB image acquisition;
- 2) Conversion in to RGB format;
- 3) Segmentation of color components that is green color segmentation;
- 4) Intensity adjustment through histogram equalization;
- 5) RGB To Gray Image conversion;
- 6) Median Filtering for noise removal;
- 7) Gray to binary conversion using Otsu’s Method;
- 8) Computing shape, size based feature calculation;
- 9) Disease segmentation.
- 10) Configuring the correct result for disease and recommendation for pesticide.

V. RESULT AND ANALYSIS

The above algorithm gives accurate result in short time, It first take RGB image convert it in to gray image for noise removal operation median filter is used to remove salt and pepper noise, then thresholding is applied in this step Otsu's Method is used, This convert the Gray image in to purely in to binary image, structuring element is applied for boundary specification. Region properties are defined for feature extraction such as shape, size, and area is defined, these all values are given to the trained matrix and then, obtained output is as follows

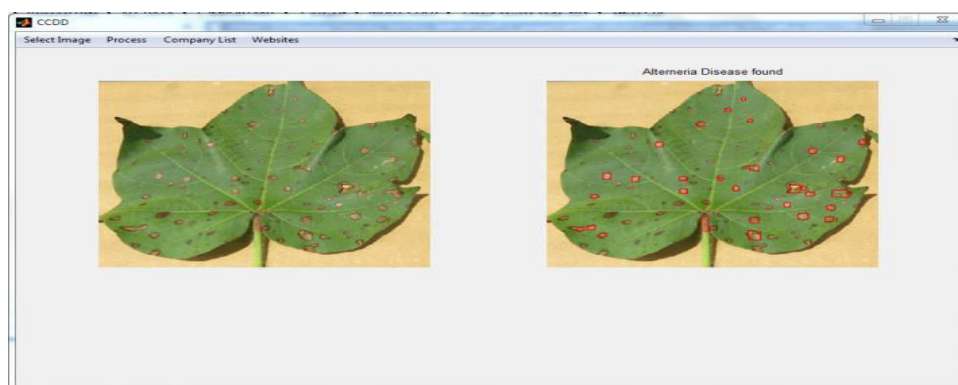

Figure 2: Alternaria disease found



Figure 3: No disease detected

VI. CONCLUSION AND FUTURE WORK

This project address how the disease analysis and pest recommendation is possible for the cotton leaf diseases detection, the analysis of the various diseases present on the cotton leaves can be effectively detected in the early stage before it will damage the whole plant, initially we can be able to detect 2-3 diseases on the cotton leaves by the methodology of eigen feature regularization and extraction technique. This motivates us to detect more possible diseases on the leaf of cotton plant. The idea utilized here is having more success rate, than that of the other feature detection technique. Also due to this method about 90% of detection of Red spot i.e. fungal disease is detected, it is most dangerous disease, it can highly affect the productivity of the cotton plant in more extent. And if it detects in early stage we can say that, we able to make better productivity. Here the model existing can able to detect the disease more accurately, The Viderbha and Marathwada Region of

Maharashtra state is main producer of cotton, where if this model is applied, we can say that, we can archive good productivity by preventing the various diseases present on the leaves of cotton plant.

VII. REFERENCES.

- [1] P. Revathi & M. Hemalatha," Advance Computing Enrichment Evaluation of Cotton Leaf Spot Disease Detection Using Image Edge detection", IEEE-20180 (ICCCNT), Coimbatore, India, 2012.
- [2] Mr. V. A. Gulhane & Dr. A. A. Gurjar," Detection of Diseases on Cotton Leaves and its Possible Diagnosis", (IJIP), Volume (5), Issue (5), 2011, Pg: No: 591-598.
- [3] Yan Cheng Zhang, Han Ping Mao, Bo Hu, Ming Xili "features selection of Cotton disease leaves image based on fuzzy feature selection techniques" IEEE Proceedings of the 2007 International Conference on Wavelet Analysis and Pattern Recognition, Beijing, China, 2-4 Nov. 2007.
- [4] P. Revathi Classification of Cotton Leaf Spot Diseases Using Image Processing Edge Detection Techniques", IEEE, International conference on emerging Trends in science, engineering & technology, 2012, pg: No: 169-173.
- [5] Viraj A. Gulhane," Disease Detection On Cotton Leaves by Eigen feature Regularization and Extraction Technique", (IJECSCE 1) 2012, pp 1-4.
- [6] <http://www.pdkv.ac.in/CottonUnit.php>(cotton area in viderbha)
- [7] <http://cotton.ces.ncsu.edu/>
- [8] <http://aiccip.cicr.org.in/Nanded.html>
- [9] <http://www.cicr.org.in/>

To Cite This Article

Naik, M.D., Vyavahare, J. A. (2016): "Cotton Crop Disease Detection and Diagnosis Using Image Processing Technique" *International Journal of Informative & Futuristic Research (ISSN: 2347-1697)*, Vol. 4 No. (4), December 2016, pp. 5901-5906, Paper ID: IJIFR/V4/E4/037.

A STUDY ON RELATION BETWEEN RETAIN MENTAL HEALTH TO ENDORSE THE RESILIENCE SKILL OF WOMEN B.ED., TRAINEES

Paper ID	IJIFR/V4/ E4/ 040	Page No.	5907-5913	Subject Area	Education
----------	-------------------	----------	-----------	--------------	-----------

Key Words	Mental Health, Resilience, Women B.Ed., Trainees.
-----------	---

1 st	Dr. M. Vasimalairaja	Associate Professor, Directorate of Distance Education, Alagappa University, Karaikudi.
2 nd	J. Gowri	Research Scholar, Department of Education Alagappa University College of Education, Karaikudi

Abstract

Mental health is a fundamental element of the resilience, health assets, capabilities and positive adaptation that enable people both to cope with adversity and to reach their full potential and humanity. The study was conducted to assess the relationship between retain the mental health to develop the resilience skill of female teachers and to explore the extent to which the results were useful in addressing potential future problems in teacher education. Using the Mental Health Scale by Singh & Sengupta (2008) and the resilience skill scale by (Connor & Davidson, 2006) a study was conducted on a sample of 100 female B.Ed., Trainee teachers of J.J.College of Education, Pudukkottai Dist, TamilNadu State. These results could sensitize prospective teachers regarding the issues of psychological wellbeing and assist them in promoting mental health among their students.

I. INTRODUCTION

Teachers are considered essential and important human resource players in education among the many others. Teachers are entrusted with the massive task and responsibility of facilitating and nurturing young people's intellectual and social development. The intellectual capabilities and social skills of children and adolescents are



affected by many factors in formative stages of their growth. One of the many factors that affect positively or negatively is mental health of the teacher. To prevent and protect children from being exposed to teachers with poor mental health, teacher must possess resilience skill. Thus it seems that to handle delicate young minds effectively and to be able to cope with the expectations of important educational stakeholders in this area such as parents and the community, a teacher needs to have good mental health and understand the harmful effects of poor mental health on teaching and learning. Good Mental Health and Good Resilience skill help the teacher to motivate and inspire the students.

Teachers having good mental health can provide an optimistic and congenial school climate to protect students from developing mental health difficulties and help them to develop sense of belongingness and connection. Teachers' resilience skills improve the student's resilience skill also. And resilience skills with their daily working environment are associated with their actual behaviour. A poor resilience skill having students in a classroom and the misconduct of pupils can have negative effects both on teachers' and pupils' general resilience and mental health status as well as on their scholastic achievement. Kidger, Gunnell and Biddle (2010) have expressed concern that if teachers' own mental health needs are neglected, they may not be aware of the mental health problems of the young people they teach.

Mental Health:

Mental health is defined as the successful performance of mental function, which results in productive activities, fulfilling relationships with other people and the capacity to adjust to changes and cope with difficulties and hardships. From early childhood until late life, mental health is considered the spring board of thinking and communication skills, learning, emotional growth, resilience for recovering quick and self esteem. A person's mental health is subject to any variety of changes in life, either from genetic causes, to environmental stressors, or physical changes that may occur during their life time (Holmes, 2006). Mental Health is the balanced development of the total personality which enables one to interact creatively and harmoniously with society (WHO, 1962). Yong and Yue (2007) in various studies show that teachers have one of the most stressful occupations. Long-term work stress may lead to burnout, which gravely affects teachers' physical and mental health, lowers the quality of their work, and, in turn, impairs their students' physical and mental health and development and imperils the sound development of education. Walley, Grothaus and Craigen (2009) found that with the array of challenges facing today's youth, school counselors are in a unique position to recognize and respond to the diverse mental health needs of students.

Resilience:

The rise of positive psychology has seen a new focus on positive constructs such as resilience. Resilience, as a concept, appears to cross national and cultural boundaries (Hunter 2001). Culturally, the concept appears to be understood as the capacity to resist or "bounce back" from adversities. Resilience theory should be a part of the educational content and taught in a way that promotes reflection and application in order to give

students strength, focus and endurance in the workplace. Resilience and similar qualities ought to be emphasized in clinical experience courses, internships, work integrated learning and other work experience courses (McAllister & McKinnon, 2008). Werner and Smith (1982) defined the concept as "the capacity to cope effectively with the internal stresses of their vulnerabilities (such as labile patterns of autonomic reactivity, developmental imbalances, unusual sensitivities) and the external stresses.

II. OBJECTIVES OF THE STUDY

The following are the objectives of the present study.

- To find out whether the Women B.Ed., Trainee differ in retain their mental health on basis of Subject Specialization. [Arts / Science]
- To find out whether the Women B.Ed., Trainee differ in retain their mental health on basis of Locality of Residence. [Rural / Urban]
- To find out whether the Women B.Ed., Trainee's differ in their resilience skill on the basis of Subject Specialization. [Arts / Science]
- To find out whether the Women B.Ed., Trainee's differ in their resilience skill on the basis of Locality of Residence. [Rural / Urban]
- To find out the significant relationship between retain Mental Health to endorse the resilience skill of Women B.Ed., trainees.

III. HYPOTHESIS OF THE STUDY

The following are the hypotheses of the present study.

- The Women B.Ed., Trainees do not differ in retain their Mental health on the basis of Subject Specialization.
- The Women B.Ed., Trainees do not differ in retain their Mental health on the basis of Locality of Residence.
- The Women B.Ed., Trainees do not differ in their resilience skill on the basis of Subject Specialization.
- The Women B.Ed., Trainees do not differ in their resilience skill on the basis of Locality of Residence.
- There is no significant relationship between retain Mental Health to endorse the resilience skill of Women B.Ed., trainees.

IV. RESEARCH METHODOLOGY

This present study utilized an analysis, literature review, questionnaires for data collection. Analysis and literature review were useful in collecting textual data from published and unpublished sources. The questionnaire method was quite useful in soliciting information from the Women B.Ed., trainee students. The survey was undertaken with the help of questionnaires designed for the purpose. We have prepared the tool with **30** items to find out the using of resilience and another tool with **30** items used to find out the level of Mental

health. While designing the questionnaires, care were taken that it has closed ended 60 numbers of questions. To enhance the response rate, “Always”, “Often” and “Sometimes” as Scales are obtained by the respondents to check using Resilience skill and retain Mental health among Women B.Ed., trainees.

Both the tools have been submitted to a panel of experts in Education and their opinions are executed in the contents of the statements in the tools. From the Pilot study of the research to establishing of the reliability of tools the Test-retest method was conducted and correlation coefficient was found to be 0.69 for the first tool and 0.72 for the second tool. Researcher visited in person and met all the women students of B.Ed., in J.J. College of Education, Pudukkottai District. Random sampling method was used for selection of sample and the sample size is 100. For interpretation descriptive analysis and differential analysis were used.

Sampling Strategy:

Distribution of the Samples interms of Subject Specialization and Locality of Residence.

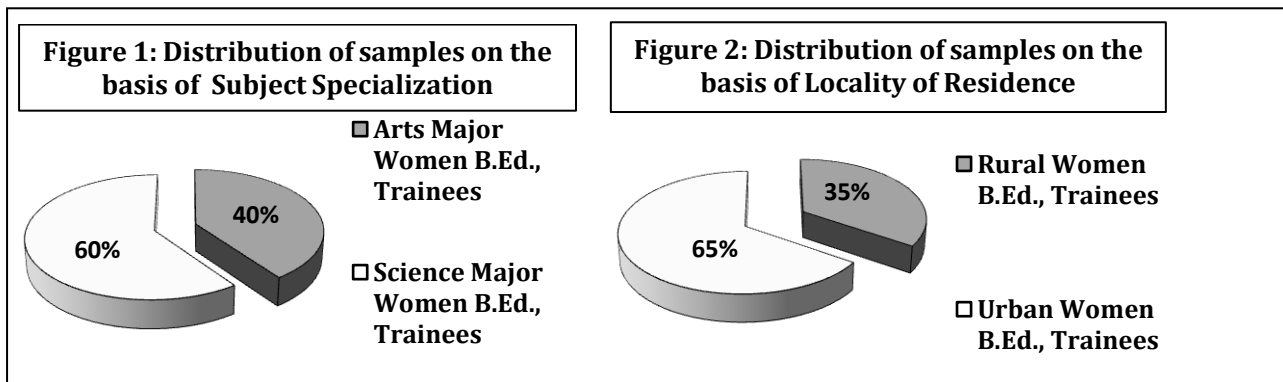

V. ANALYSIS AND INTERPRETATION OF DATA

Hypothesis-1: *There is no significant difference in retain their mental health on the basis of Subject Specialization among Women B.Ed., Trainees.*

Table 1: Difference between Arts and Science major Women B.Ed., trainees in retain their Mental Health.

Subject	N	M	SD	't' value	Level of significance
Arts	40	70.76	3.10	9.9630	Significant
Science	60	76.43	2.24		

The calculated 't' value 9.96 is greater than the table value 2.62 at 0.01 level of significance. It is inferred that, there is significant difference in retain their mental health on the basis of Subject Specialization among Women B.Ed.,Trainees. Hence the null hypothesis is rejected.

Hypothesis-2: *There is no significant difference in retain their mental health on the basis of Locality of Residence among Women B.Ed., Trainees.*

Table 2: Difference between Rural and Urban Women B.Ed., trainees in retain their mental health.

Subject	N	M	SD	't' value	Level of significance
Rural	35	66.54	3.10	6.4554	Significant
Urban	65	70.38	4.24		

The calculated 't' value 6.46 is greater than the table value 2.62 at 0.01 level of significance. It is inferred that, there is significant difference in their mental health on the basis of Locality of residence among Women B.Ed., Trainees. Here, average of Rural is lesser than the Urban. Hence the null hypothesis is rejected.

Hypothesis-3: There is no significant difference in their resilience skill on the basis of Subject Specialization among Women B.Ed., Trainees.

Table 3: Difference between Arts and Science major Women B.Ed., trainees in their resilience skill.

Subject	N	M	SD	't' value	Level of significance
Arts	40	67.32	4.10	4.0483	Significant
Science	60	70.54	3.57		

The calculated 't' value 4.05 is greater than the table value 2.62 at 0.01 level of significance. It is inferred that, there is significant difference in their resilience skill on the basis of Subject Specialization among Women B.Ed., Trainees. Here, average of Arts is lesser than the Science. Hence the null hypothesis is rejected.

Hypothesis-4: There is no significant difference in their resilience skill on the basis of Locality of Residence among Women B.Ed., Trainees.

Table 2: Difference between Rural and Urban Women B.Ed., trainees in their resilience skill.

Subject	N	M	SD	't' value	Level of Significance
Rural	35	65.67	6.8	7.1862	Significant
Urban	65	74.45	3.34		

The calculated 't' value 7.19 is greater than the table value 2.62 at 0.01 level of significance. It is inferred that, there is significant difference in their resilience skill on the basis of Locality of residence among Women B.Ed., Trainees. Here, average of Rural is lesser than the Urban. Hence the null hypothesis is rejected.

Hypothesis-5: There is no significant relationship between resilience skill and Mental Health among Women B.Ed., trainees.

Table 5: Relationship between resilience skill and Mental Health among Women B.Ed., trainees.

No.	Σx	Σy	Σx^2	Σy^2	Σxy	Correlation co-efficient	Level of Significance
100	5466	6496	213126	435267	222141	0.89	Strong Relationship

From the correlational value it is inferred that there is a strong relationship between resilience skill and Mental Health among Women B.Ed., trainees. Hence the null hypothesis is rejected.

VI. MAJOR FINDINGS:

- The Women B.Ed., Trainees differ in their resilience skill on the basis of Subject Specialization. Hence, Science students having more resilience skill compared to Arts students.
- The Women B.Ed., Trainees differ in their resilience skill on the basis of Locality of Residence. Hence, Urban students having more resilience skill compared to Rural students.
- The Women B.Ed., Trainees differ in retain their Mental health on the basis of Subject Specialization. Hence, Science students having high level of mental health compared to Arts Students.
- The Women B.Ed., Trainees do not differ in retain their Mental health on the basis of Locality of Residence. Hence, Rural and Urban students having same level of mental health.
- There is a significant relationship between Usage of Resilience skill and retain the mental health among Women B.Ed., trainees. The students having resilience skill who maintained good mental health.

VII. CONCLUSION

On the basis of results reported above, it can be concluded that mental health and usage of resilience skill are related. i.e. Usage of resilience skill will lead to good attitude or psychological well-being will improve the mental health. This shows that teachers having good mental health are happy, sociable, jovial and emotionally stable with support of resilience. The teachers who are mentally healthy will accept challenges, make efforts for personal development and strive for the growth of their students. And both these variables are having strong relationship between them.

VIII. REFERENCES

- [1] Graham, A., Phelps, R., Maddison, C., & Fitzgerald, R. (2011). Supporting children's mental health in schools: Teacher views. *Teachers and Teaching: Theory and Practice*, 17(4), 479-496.
- [2] World Health Organization (1962). WHO Tech. Rep. Ser No.9.
- [3] Wolin, S. J., & Wolin, S. (1993). *The resilient self: How survivors of troubled families rise above adversity*. New York: Villard Books.
- [4] Werner, E. E. (1 995). Resilience in development. *Current Directions in Psychological Science*, 3, 81 -85.
- [5] www.shodh.net
- [6] www.cjlt/article/view.498/229.
- [7] www.ijsrp.org/research.../ijsrp-p/0/2.pdf



[8] www.indianresearchjournal.com/.../9.pdf

To Cite This Article

Vasimalairaja, M., Gowri, J. (2016): “: A Study On Relation Between Retain Mental Health To Endorse The Resilience Skill Of Women B.Ed., Trainees” *International Journal of Informative & Futuristic Research (ISSN: 2347-1697)*, Vol. 4 No. (4), December 2016, pp. 5907-5913, Paper ID: IJIFR/V4/E4/040.

